

# HYDAC INTERNATIONAL

## Components, Systems and Service for Machine Tools

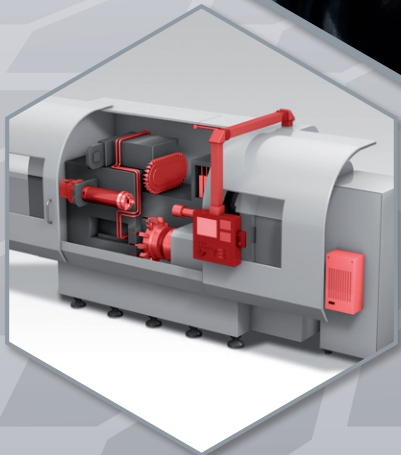
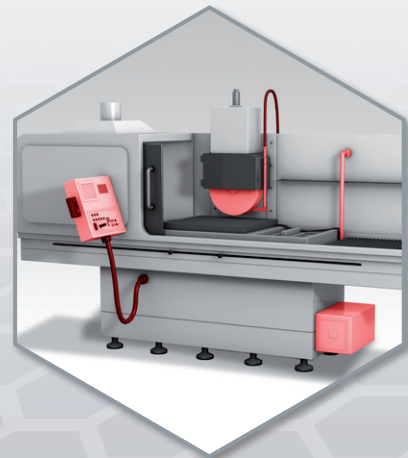
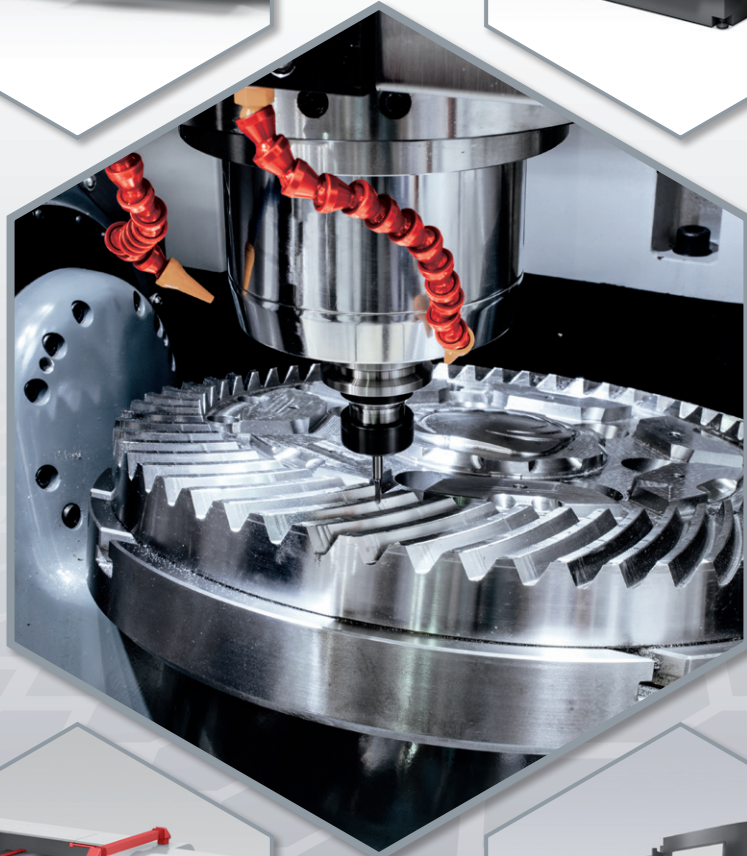
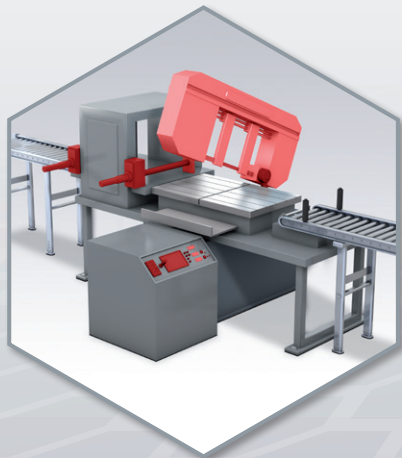
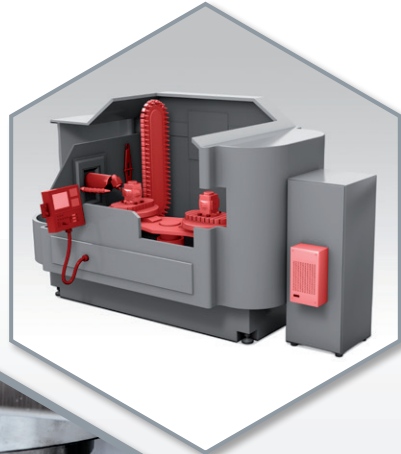
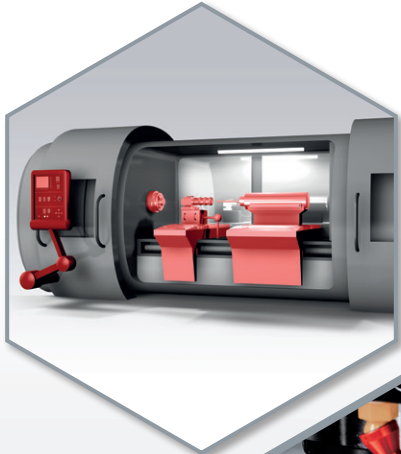

With almost 60 years experience and more than 9,500 employees worldwide, HYDAC is one of the leading suppliers of fluid technology, hydraulics, electronics and cooling equipment.

The breadth and depth of our product range, combined with our recognised expertise in development, manufacturing, sales and service, allow us to provide solutions worldwide for the diverse range of challenges in the machine tool industry.

## Your Benefits

### Global yet local

Over 50 subsidiaries and more than 500 sales and service partners – everything from a single source.

### Your partner in the automotive industry

Worldwide certification with MROs & OEMs.

### System solutions

HYDAC offers intelligent systems with its combinations of leading technological components. With the know-how of over 900 engineers in Research and Development in Germany alone.

### Leader in innovation

HYDAC is a leader in innovation and product development.

## HYDAC and Industry 4.0

HYDAC offers a wide range of products, hardware and software solutions and services. We also possess an in-depth knowledge of applications, making us an ideal partner for all kinds of industry 4.0 developments.

For machine and system operators this means, for example, higher system availability and increased productivity through the use of:

- Sensors for fluid monitoring (including particle contamination, oil condition, pressure, position, level, temperature, nominal flow)
- Data recorders and measuring equipment for the parameterisation and analysis of smart sensors
- Sensors, controls, hardware and software for predictive maintenance
- Network interface modules for connecting to the control levels and the Internet of Things
- Worldwide service and supply of spare parts, maintenance contracts and service concepts

## Hydraulics

- Compact power units
- Speed-controlled power units
- Valve stacking systems
- Hydraulic accumulators

## Cooling

- Fluid/air cooling systems
- Fluid/water cooling systems
- Cooling units
- Cold plates

## Accessories

- Coaxial valves
- Ball valves
- Mounting technology
- Service

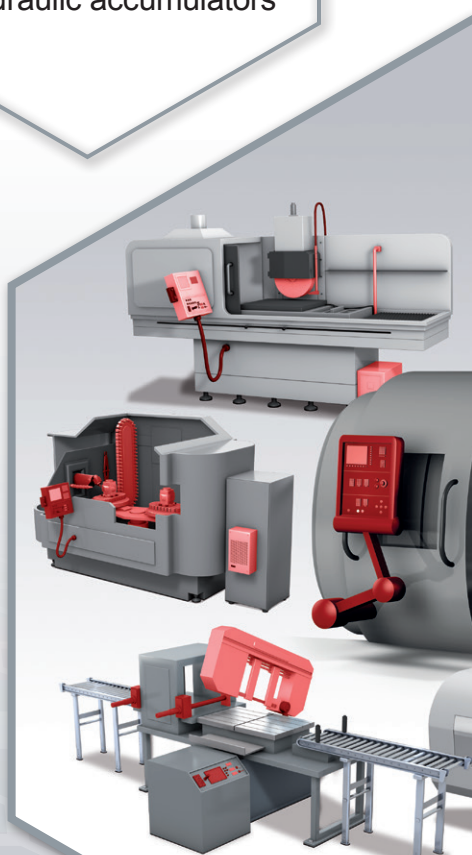

## Filtration

- Standard filters and special filters
- Oil, water and gas filtration
- Separation of solids, gases and fluids

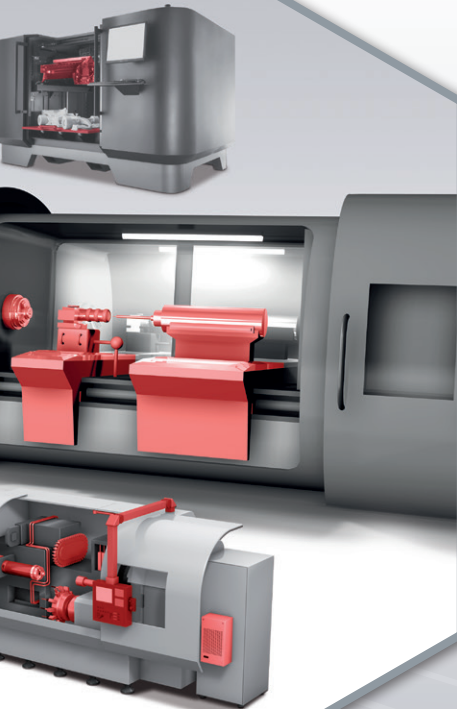

## Electronics

- Sensors (IO-Link, smart) & Condition Monitoring
- Network interface modules
- Measuring equipment and data recorders
- Accessories

## Digitalisation

- IO-Link communication
- Cloud computing
- Edge computing

## Our Services

Our customers' requirements define the scope and complexity of our solutions.

Our products range from individually designed components right up to complete systems for specific functions.

All components and systems are developed and implemented in-house.

## Our Expertise

The HYDAC industry and product specialists are able to draw on years of experience in the development and implementation of customised projects.

Our colleagues also benefit from the interdisciplinary, worldwide network of expertise, innovation, standard of quality, customer focus and service, of which they themselves are a part.

## Fluid Engineering and Service

The wide and tried-and-tested range of components and systems for condition monitoring as well as fluid care and monitoring is complemented by the HYDAC CMX hardware and software suite for the digitalisation of complex processes.

A worldwide service network of local specialists works with you in close partnership and provides support in installation, commissioning, maintenance and training.



## Innovative Solutions for Machine Tools

HYDAC can solve a range of problems for you in the machine tools industry – as your partner for new developments or for retrofitting existing systems.

The different components, systems and subsystems from our various product divisions generate a unique range of products for you which are complemented by industry-specific and customer-specific solutions.

A wide range of fluid engineering and other services available globally yet locally enable us to be your complete service partner for all the requirements relating to:

- **Hydraulics**
- **Filtration**
- **Cooling**
- **Electronics**
- **Accessories**
- **Digitalisation**

### Sensors & Condition Monitoring

Sensors for measuring pressure, differential pressure, position, temperature, level, flow rate, humidity and oil degradation.

- Bidirectional communication via IO-Link
- Smart sensors with added benefits:
  - Storage of diagnosis information in the sensor
  - Measurement range and device temperature monitoring
  - Automatic self-parameterisation
  - Remote diagnosis, remote maintenance



### Measurement technology

Measuring devices/data recorders for data collection and analysis, sensor parameterisation and data storage.

- Up to 38 sensors can be connected
  - Up to 100 measurement channels can be displayed in parallel
  - IO-Link interface for parameterisation
- Programming adapter for programming HYDAC sensors in connection with a PC.



## HYDAC CMX

### Your way to "industry 4.0"

The HYDAC CMX hardware and software suite prevents downtimes with local and central condition monitoring of systems/components. The improved system knowledge enabled by "transparent machines" also increases efficiency.

- Easy integration
- Collection, interpretation and preparation of data
- Early detection of imminent damage, recommended actions, fault localisation



### 8 watt directional control valve

Valve with special coil for direct control via the machine control.

- Direct actuation via the machine control (e.g. PLC)
- Saves the need for power electronics for valve control
- Reduced energy requirements for the valve technology



### Coaxial valves CX plug-in

Patented design enables easy exchange of CX valves.

- Can be used as a standard part or as a spare part
- Significant reductions in service times and downtimes
- Functional safety of the unit under inspection



### Valves with switch position monitoring

Valves with an integrated sensor (hall principle) including analogue or IO-Link output.

- System monitoring and an increase in the diagnostic coverage
- Information is provided about switching cycles

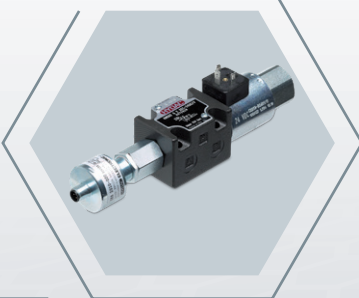

### MULTI approval accumulators

Hydraulic accumulators with multiple approval classes for use almost everywhere worldwide.

- Versatile for original equipment manufacturers and in the spare parts business
- Clear documentation
- Optimised storage and logistics management

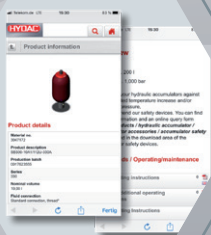

### Online documentation for hydraulic accumulators

Access to all product-specific accumulator documents via a QR code on the accumulator.

- 24 hours a day → 7 days a week → 365 days a year → available worldwide
- Please visit our microsite at: <https://accumulator-dokumentation.hydac.com>





### FWKS fluid/water cooling system

Efficient fluid cooling for drives, motor spindles, converters or gear boxes.

- Cooling below the ambient temperature is also possible
- Low heat dissipation and low noise emission
- With thermostatically or electronically regulated proportional valve for maintaining the required temperature level



### FLKS fluid/air cooling system

Efficient fluid cooling via ambient air.

- Compact and low maintenance
- Energy efficient as optimised drives are used and heat is dissipated directly to the environment
- Speed-controlled systems which maintain the temperature of the operating medium at a set difference to the ambient temperature

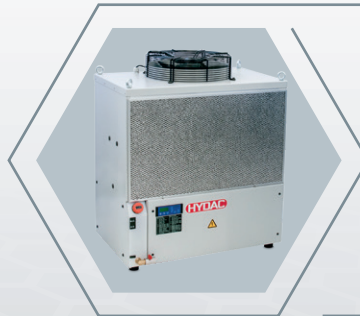

### RFCS cooling unit

Efficient fluid cooling tailored to the customer.

- Process media can be cooled below the ambient temperature without an external coolant
- As a compact auxiliary unit or for integration into a machine
- Stand-alone control of the system due to innovative controller design

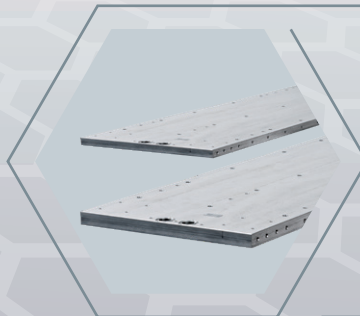

### Cold plate

Fluid cooling plates for cooling power electronics, batteries, laser sources etc.

- Customer-specific design and construction
- Manufactured in solid aluminium and joined with high-quality joining processes such as vacuum brazing and friction stir welding
- Dimensions of up to 1,600 mm x 750 mm possible



### Fluid panel

Customised, self-supporting unit which combines all the fluid control components of a machine tool.

- Quick and easy installation through the use of defined hydraulic, pneumatic and electronic interfaces
- Self-supporting system enables easy integration during machine assembly at the customer's location
- Everything from a single source – reduces number of interfaces and minimises number of suppliers

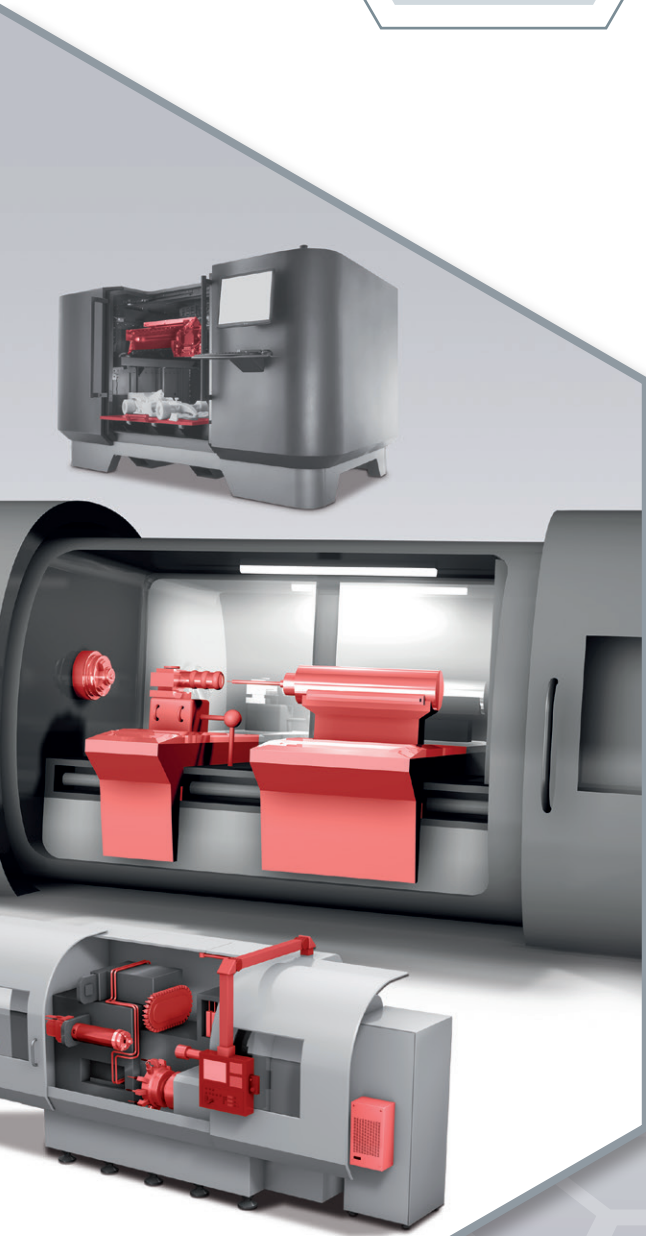

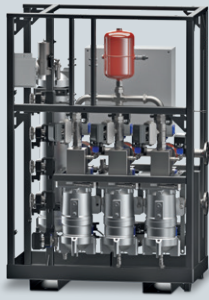

### HYDAC FlushPACK

Innovative filter concept for selective manufacturing processes.

- Maximum occupational health and safety during filter change and disposal
- Easy and inexpensive disposal
- Improved ease of maintenance
- Standardisation – one filter system for all powder materials
- Long filter service life
- High potential for savings

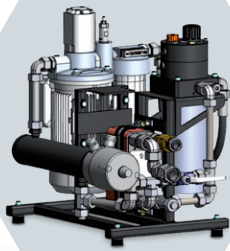

### FAM 1 dewatering module

Compact degassing and dewatering unit with offline filter.

- Reliable dewatering far below the saturation point
- Simultaneous degassing of the oil
- Reliable and inexpensive removal of solid particles
- Durable und industry-compatible design



### Circular saw unit

Compact unit for saw applications.

- Unit includes return line filter
- Variable displacement vane pump
- Control blocks for clamping cylinders and support cylinders
- Includes hydraulic accumulators



### KineSys clamping power unit

Combined, variable-speed operation with accumulator charging function based on the DVA Kit.

- Fully parameterised Plug & Play unit
- HFI-MM motor-mounted frequency inverter
- Pressure-controlled operation
- Integrated start/stop function



### HYDAC tank optimisation

Innovative filter concept with degassing function for optimised air removal.

- Optimised filter-tank complete system
- Reduced system costs
- Reduced installation space and complexity
- Conservation of resources
- Optimised reliability of your system



### Automatic filter AutoFilt® RF4

Efficient protective filtration for machine tools.

- Fully automatic filtration in a compact design
- Open connectivity to all commonly used customer interfaces and possibility of remote monitoring via a smartphone or tablet
- Also available as an all-in-one solution for high-pressure cooling lubricant supply for machine tools



HYDAC Headquarters Germany

# Global Presence. Local Expertise. [www.hydac.com](http://www.hydac.com)



HYDAC China



HYDAC USA



HYDAC Japan



HYDAC Korea



HYDAC India



HYDAC Czech Republic



HYDAC Poland



- 📍 HYDAC Headquarters
- HYDAC Companies
- HYDAC Sales and Service Partners
- ▲ Free Sales Partners



## INTERNATIONAL

**HYDAC INTERNATIONAL  
GMBH**

Industriegebiet  
66280 Sulzbach/Saar  
Germany

Tel.: +49 6897 509-01  
Fax: +49 6897 509-577

E-mail: [werkzeugmaschinen@hydac.com](mailto:werkzeugmaschinen@hydac.com)  
Internet: [www.hydac.com](http://www.hydac.com)

Further  
information



### Note

The information in this brochure relates to the operating conditions and applications described. For applications and/or operating conditions not described, please contact the relevant technical department. Subject to technical modifications.