

HYDAC INTERNATIONAL

**Components,
Systems and Service
for Thermal Power Plants.**





HYDAC China



HYDAC India



HYDAC USA



HYDAC Poland



HYDAC Brazil



HYDAC Austria



HYDAC France



HYDAC Norway



HYDAC Switzerland



Your expert partner for thermal power plants.

With over 7,500 employees worldwide, HYDAC is one of the leading suppliers of fluid technology, hydraulics, process technology and electronic equipment.

Our broad range of products, combined with our expertise in development, manufacturing, sales and service enables the wide range of requirements in thermal power plants to be met worldwide.

Our quality and environment certification to ISO 9001/2000 and ISO 14001 denote first class quality and responsible management of our resources.

Global yet local.

With over 45 overseas companies and more than 500 sales and service partners, HYDAC is your reliable partner worldwide.

System solutions. One supplier. One contact.

Wherever you need us, we are there to help you find the most effective solution – for every application, from components to a complete system.

World-wide specifications and approvals.

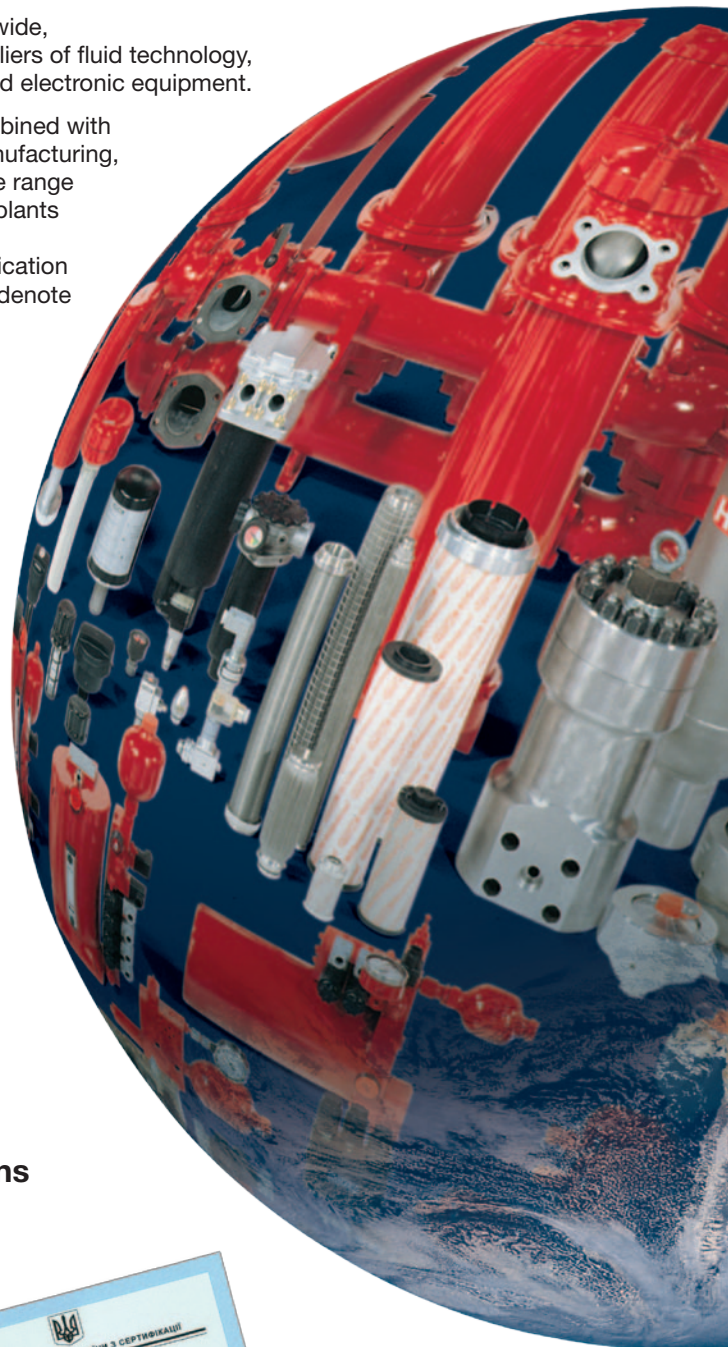

Fluid technology for the thermal energy sector.

Power generation from thermal power plants will continue to play an important role in the long-term when it comes to guaranteeing supply security.

This power capacity can be achieved through new-build or by retrofitting old plant.

In recent times, the industry has seen a huge increase in retrofitting in particular, thus necessitating, of course, improvement in plant efficiency. For the hydraulic and lubrication systems used, this signifies continuous product optimization, even at the component level, optimized and integrated product solutions and sustainable system cost reductions.

For this reason, HYDAC provides a comprehensive portfolio combining technology, products and service covering all aspects of thermal power plant technology.

In this regard, our key focus is on providing a complete fluid technology approach for our customers in the form of system solutions. We already offer integrated product and service solutions in all areas of power generation: from hydraulic control systems for gas and steam turbines, bearing and drive lubrication systems of generators, turbines and compressors, right up to gas and liquid fuel filter systems.

Needless to say, an important part of an integrated solution in fluid technology is a comprehensive product range for service tasks like fluid monitoring and conditioning, for example. Provision of service units, measuring equipment and manpower for service assignments across the globe also forms part of our business.

We offer:

- Global presence in power plant technology and service in all aspects of oil hydraulics, project-specific design of hydraulic systems and fluid-power solutions in compliance with global power plant standards and regulations.

- Cost optimization achieved through customized system solutions using standard components for fluid technology.

In addition we can offer a complete range of products for condition monitoring of hydraulic and lubrication oil circuits as well as full service packages, worldwide, for:

- Electro-hydraulic systems
- Oil systems for bearing and turbo drive lubrication
- Hydraulic lifting systems (start, stop, review)
- Automatic water filtration systems for cooler and nozzle protection, for waste gas (NOX) and ash treatment

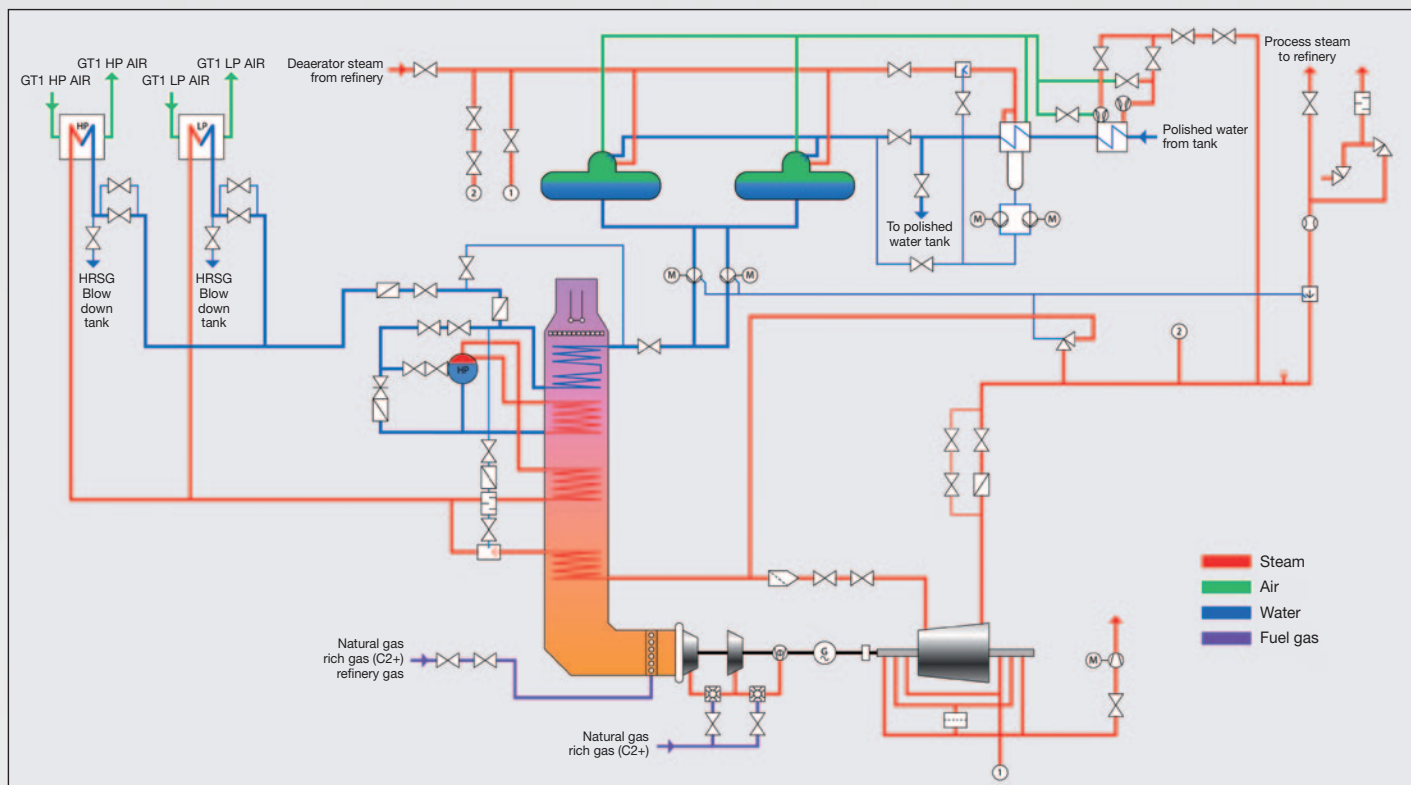

1 Transformer Care

- Continuous degassing of the insulation oil
- Continuous dewatering of the insulation oil
- Continuous filtration, increase in disruptive voltage and life cycle extension of the insulation oil

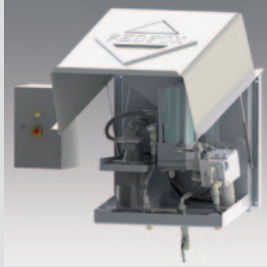

TCU TransformerCare Unit



Cooling and sealing water treatment

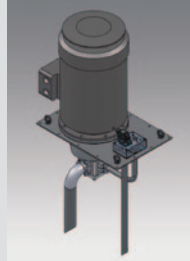

Lift system



PWT Plate heat exchanger for use in generator lubrication systems

2 Generator

- Lubrication / Cooling systems
- Lifting systems, also with redundancy as standard solution
- Filter / Cooling systems, also for retrofitting
- Piston and bladder accumulator stations for emergency function lubrication

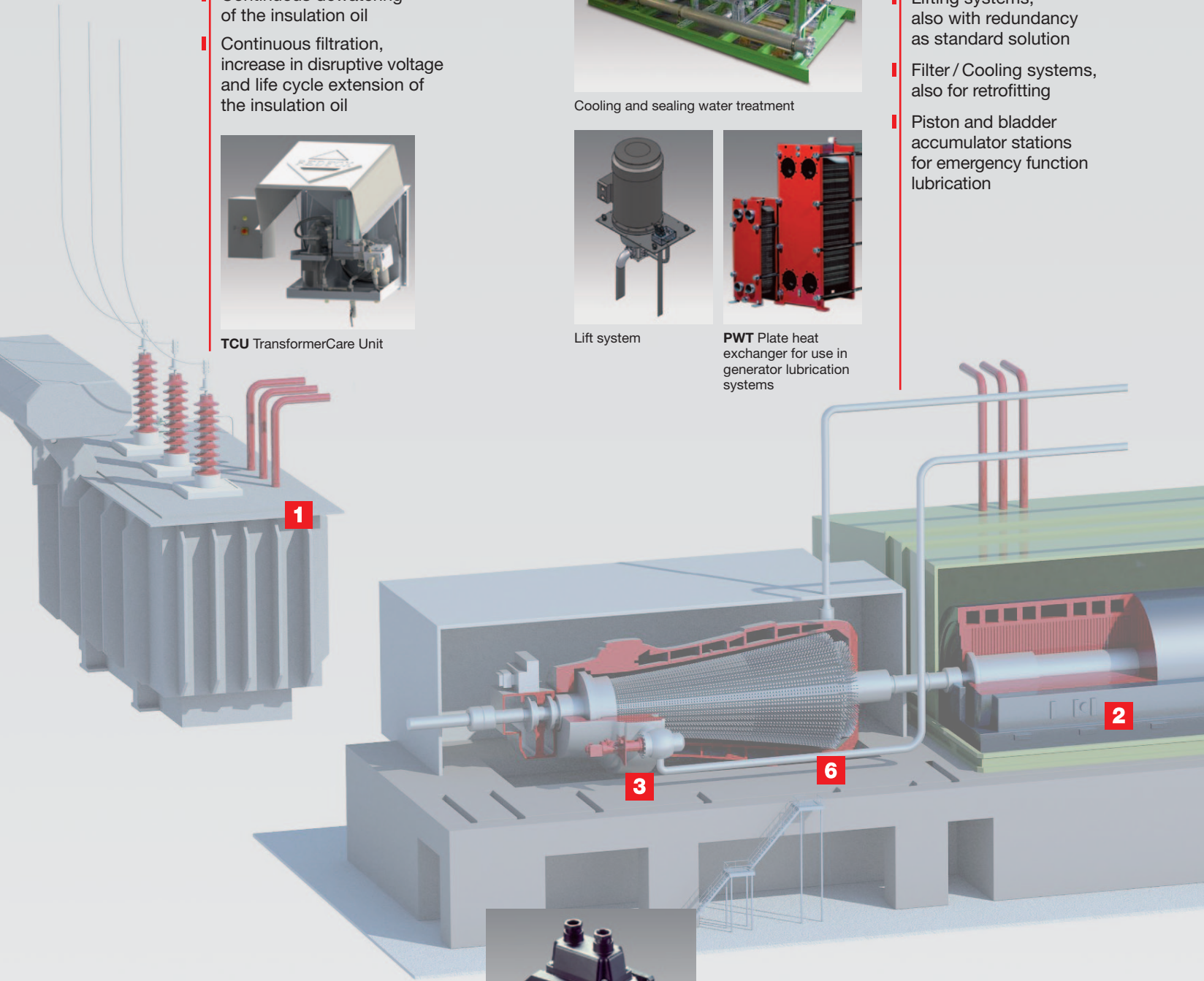

SIL
SAFETY LEVEL
INTEGRITY



EHC-AA
Free-standing electro-hydraulic control device



EHC-A / EHC-S
Electro-hydraulic drive system with safety control



Oil supply, supply unit for oil supply in turbine controls



EDS 1700
Electronic pressure switch

3 Steam Turbine Control

- Electro-hydraulic safety controls EHC according to IEC 61508 and IEC 61511
- Safety controls EHC-S, modular construction using standard components (SIL-enabled)
- Drive concepts EHC-A, also as free-standing drives EHC-AA (SIL-enabled)
- Electro-hydraulic oil supply unit EHC-U

4a Fuel Gas Filtration

PRFS inline filter in carbon steel or stainless steel version or as FGS fuel gas module as installation-ready system:

- Fuel-gas filter
- Main component in the fuel package



FGS Fuel Gas Module



PRFS Inline filter

4b Fuel Oil Filtration

RFLD 4000 duplex filter for use as:

- Fuel-oil filter
- Main component in the fuel package



RFLD 4000 Duplex inline filter

5 Compressors

HYDAC Gas Coalescer Filter GCF:

- Cleaning and conditioning of sealing gas
- Reducing wear and tear on sealing gas seals

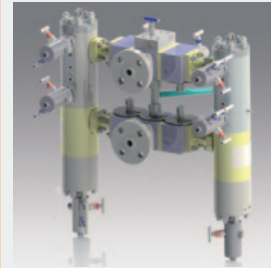

GCF Gas Coalescer Filter

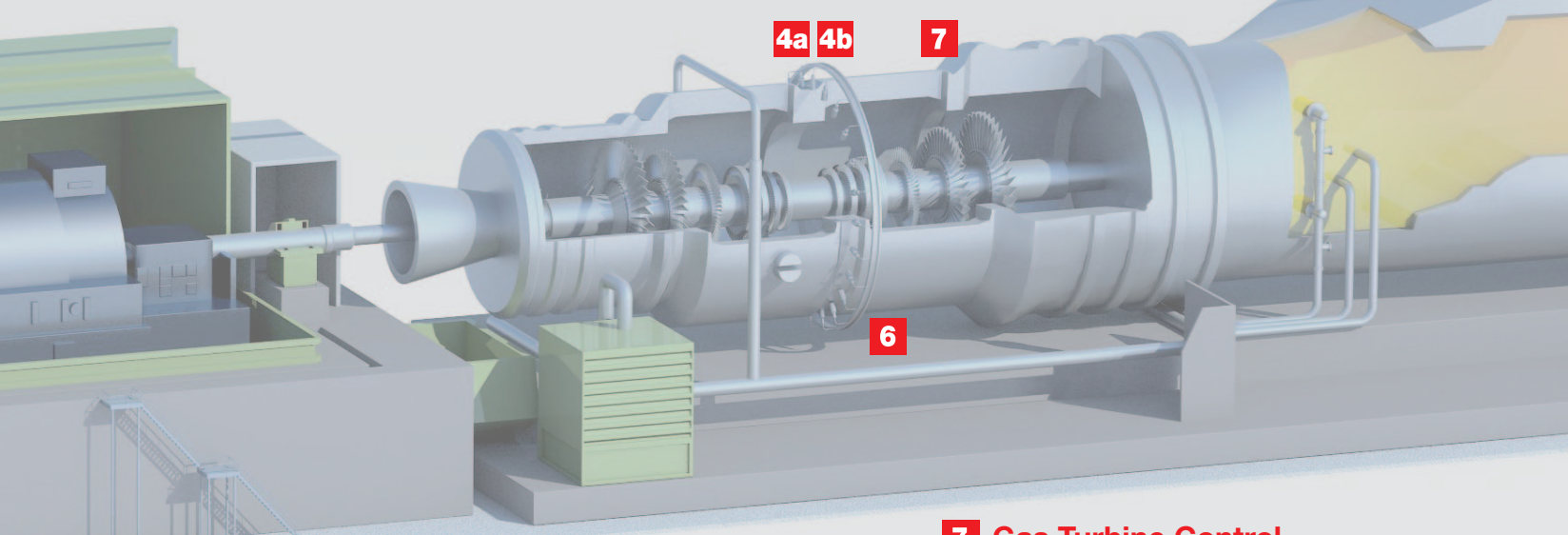

Bearing lubrication and lift system



Bladder accumulator station for bearing lubrication and emergency oil supply

6 Turbine / Generator Lubrication

Modular oil systems for bearing lubrication of turbine and generator as well as for turbo transmissions:

- Standard lifting systems (also as redundant model)
- Bladder and / or piston accumulator stations for emergency lubrication



(API) AFLD 2702 Lubrication oil filter



AS 1000 Water sensor

7 Gas Turbine Control

- Electro-hydraulic safety controls EHC according to IEC 61508 and IEC 61511
- Safety controls EHC-S, modular construction using standard components (SIL-enabled)
- Drive concepts EHC-A, also as free-standing drives EHC-AA, cost-optimised using modular system (SIL-enabled)
- Modular hydraulic units for controlling the drives and improving turbine efficiency levels EHC-U



EHC-A Electro-hydraulic drive system



EHC-U Modular hydraulic power unit

8



8 Flue Gas Conditioning

AutoFilt® RF3 automatic back-flushing filter and OK-EL oil-air cooler

- Water filtration for nozzle protection on NOX systems
- OK-EL oil-air cooler use in NOX systems

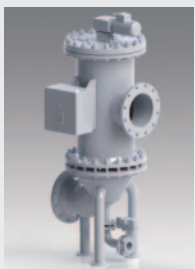

RF3 Automatic back-flushing filter

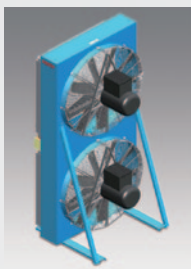

OK-EL Oil-air cooler



AutoFilt® RF3 Automatic back-flushing filter (cooler protection)



FAM FluidAquaMobil mobile unit for dewatering, degassing and filtration



OLF60CM
with sensor system



FCM
FluidCleaner Mobil



Optimicron® Power
Filter element



Stat-Free®
Filter element



VMU VarnishMitigating Unit and **IXU** Ion eXchange Unit

9 Secondary Functions / Service, Balance of Plant (BoP)

Treatment of water-based media

Automatic back-flushing filter for boiler feed-water treatment (filtration) in the water/steam cycle.

- Cooler protection
- Nozzle protection (e.g. sprinkler system)
- Sealing water filtration for seal protection

Treatment and conditioning of hydraulic and lubricating media

- Oil-conditioning units FluidAqua Mobile FAM dehydrating, degassing, and filtering hydraulic and lubrication fluids.

Fluid conditioning units for separating solid particle contamination from hydraulic and lubricating media

- Stationary power units (e.g. OLF offline filter)
- Mobile power units (e.g. FluidCleaner Mobil)
- Optional: Integrated fluid sensors

HYDAC filter elements Optimicron® Power and Stat-Free®

- Specially developed for use in modern, low conductivity oils and fire-resistant fluids

VMU VarnishMitigation Unit for treating mineral oils

- Removal of oil ageing products (varnish)
- Ion eXchange Unit IXU for treating fire-resistant fluids

Fluid Engineering and Service – Worldwide.

User accessories

HYDAC has a comprehensive and proven range of condition monitoring products, components and systems designed for fluid care and monitoring as well as for the technical cleanliness of components.



Condition Monitoring

HYDAC offers a comprehensive range of Fluid Monitoring equipment for online monitoring of critical fluid parameters. So it makes a significant contribution to the safe operation of the turbine hydraulics and the lubrication.



FAM Dewatering Unit

Undesirably high levels of process steam and water enter the oil circuit, particularly on lubrication oil systems of steam and water turbines.

This has a drastic effect on fluid ageing and lubrication properties. By using FAM dewatering and filtration units continuously during system operation, integrated conditioning of the lubrication media is assured.



VarnishMitigating Unit VMU

The service-friendly VarnishMitigation Units VMU are used to condition mineral oils. They are particularly effective at removing oil ageing products (varnish) from mineral oils. The removal of varnish is on the basis of adsorption on an active surface.



Optimicron® Filter Elements

When used in power plant applications such as turbine lubrication or in the lift system of the turbine, specific requirements are demanded of the filter elements. The Optimicron® Power elements achieve an optimum pressure differential with a high filtration rating during filtration and comply with the API Standard 614 / ISO 10438. In addition, the outer sleeve has a new type of perforation which ensures exceptionally high tensile strength.

Electrostatic charging in the system is safely prevented by the new Stat-Free® technology which is also incorporated into the new Optimicron® Power elements.

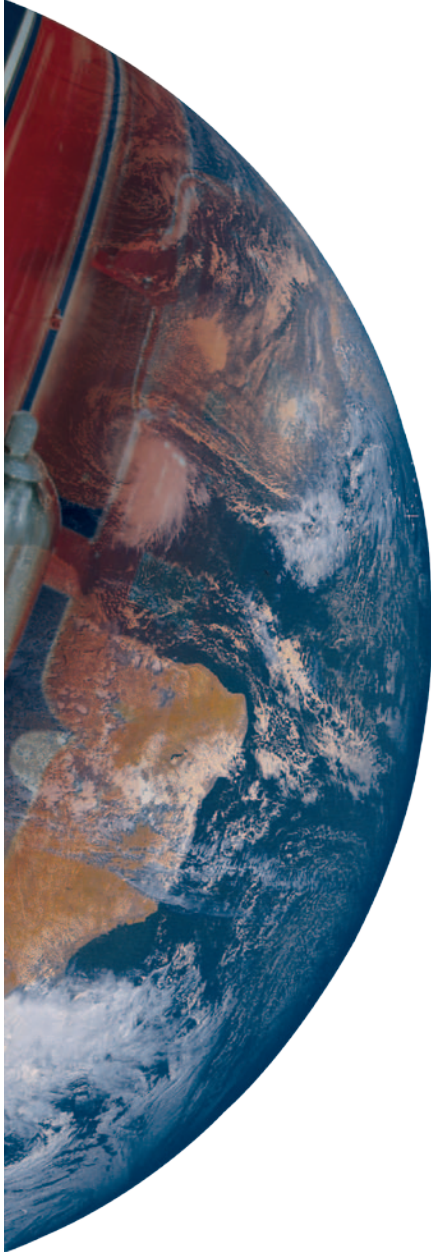



Accumulators DEF 30.000

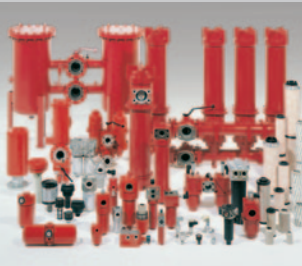

Filter Technology DEF 70.000



Process Technology E 77.000



Fluid Service DEF 79.000



Compact Hydraulics DEF 53.000



Accessories DEF 61.000



Electronics DEF 180.000



Cooling Systems DEF 5.700

Global Presence, Local Expertise. www.hydac.com

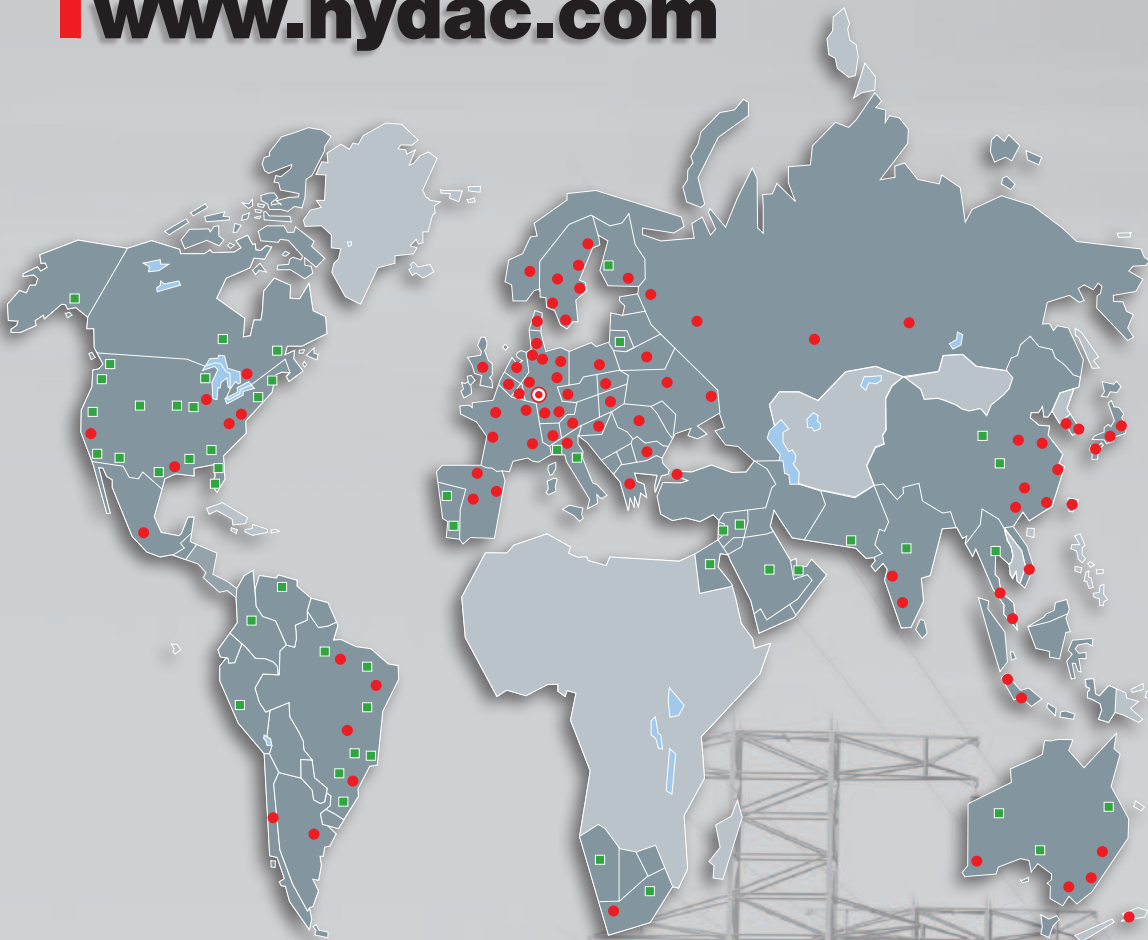

- HYDAC Headquarters
- HYDAC Companies
- HYDAC Sales and Service Partners

HYDAC INTERNATIONAL

Head Office
HYDAC INTERNATIONAL
GMBH

Industriegebiet
66280 Sulzbach/Saar
Germany

Tel.: +49 6897 509-782
Fax: +49 6897 509-577

E-mail: powerplants@hydac.com
Internet: www.hydac.com