

Organ des Forums Mobile Maschinen im VDMA

Design und Konstruktion  
Virtuelle Prozess- und Komfort- und Fahrdynamikoptimierung

**HYDAC  
SPECIAL  
EDITION**

einer robusten Technologie

ieren heterogene Safty-Level

und Vorberichte zur Agritechnica 2013



**Stark verbunden:**

Heavy-Duty-Leitungen  
für den Tagebau

# Hydraulic Hybrid Drives

Increased efficiency based on robust technology

**AGRI  
TECHNICA**  
The World's No.1

Halle 1, Stand B 128



Frank Bauer

*The motivation for using hybrid technology generally extends far beyond merely increasing the energy efficiency of machines, with the result that the additional costs of the machine pay for themselves relatively quickly. Given the considerable robustness, the relatively low investment costs and simple operation, hydraulics has a great opportunity to participate fully in this new technology. The present article describes the basic principles of hybrid technology and explains with the aid of a practical example the relatively simple route to success with HYDAC.*

## What are hybrid drives and where do you find them?

Hybrid drives have at least two drive sources which can supply energy independently of each other. They are most widely used in the automotive industry where the internal combustion engine is supported by an electric drive train, including battery power. The motivation behind hybrid technology ranges from start-stop functions, the oppor-

tunity to change the operating point and to downsize the combustion engine, right through to regenerative braking.

Driven by the massive pressure to increase efficiency and the current legal position to comply with the emissions directives, hybrid technology is also being discussed and deployed in mobile machinery. As mobile machines, as a rule, already have hydraulic drive trains, to include an accumulator in the hybrid structure seems obvious, espe-

**Dr. Frank Bauer**, Divisional Manager for  
Accumulator Technology,  
HYDAC Technology GmbH, Sulzbach



Fig. 1: HYDAC Product portfolio for hybrid applications

cially since electrical drives using batteries do not meet all the requirements regarding safety, robustness and cost. Examples here are the mobile excavator from Caterpillar, the cable operated excavator from Liebherr or the hydraulic start-stop system of Atlas Weyhausen, all of which are equipped with a hydraulic drive train and were unveiled at the Bauma 2013 Exhibition in Munich. [1]

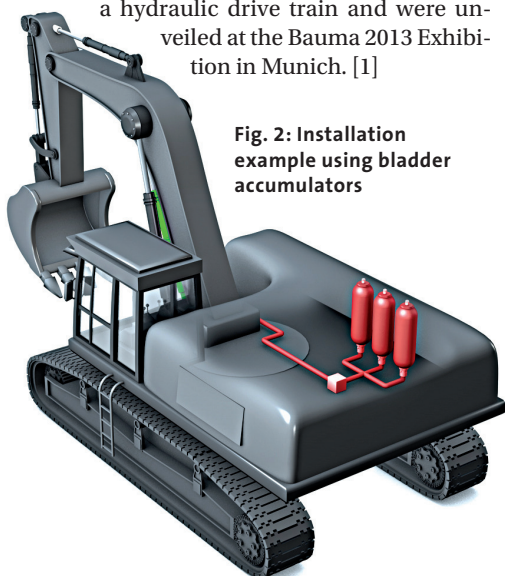

Fig. 2: Installation example using bladder accumulators

## What are the beneficial characteristics of the accumulator?

Hydraulic accumulators have an enormous power density. In other words, the stored energy in the form of compressed nitrogen can be transferred back to the oil very quickly and without significant losses, via the separating element (piston, bladder or membrane). The energy is thus available in its „purest“ form and can be converted directly by the hydraulic motor into torque required for the drive train, or by the cylinder into force. Further energy changes and associated losses therefore no longer occur. Of particular interest is the use of the accumulator during highly dynamic braking processes where several 100 kW have to be converted (Fig. 3). Since accumulators have been used in mobile machines for many decades (suspension, braking and steering systems), the hydraulic hybrid approach is also welcomed by the machine builder and operator. They have maintenance and service personnel who are very experienced in hydraulic accumulators and who will not have to be specially trained.

In addition, numerous safety devices, such as for example, pressure relief valves, bursting discs, temperature fuses etc are available.

Finally, there is also the cost perspective which provides crucial momentum for a new technology. If one takes the whole hybrid drive train from the accumulator to the displacement elements, including peripherals (valves, tank, clamps), according to the machine builders, a payback period of between one and two years is achievable. Electric hybrids on mobile machines are currently still a long way from achieving this.

## From the load compensation system to the gas cylinder

A nice example of a hybrid drive train is the load compensation system of a material handling machine. These machines are used, for example, to handle scrap and bulk goods in ports and are in operation for up to 24 hours per day. As a result of the long and heavy booms, the base load which has to be absorbed by the lifting cylinders in the form of pressure is relatively high (100 - 150 bar), even before a payload is lifted by the grab or hook. A simple option for compensating this load is to install an additional cylinder which is pre-charged by an accumulator, thus equalising this base load (Fig. 4).

With the aid of an appropriate sizing program which takes into account both the drive kinematics of the compensating cylinder and the thermodynamics of the accu-

# HYDAC

**Fluid Technology,  
Hydraulics,  
Electronics and  
Service. Worldwide.**

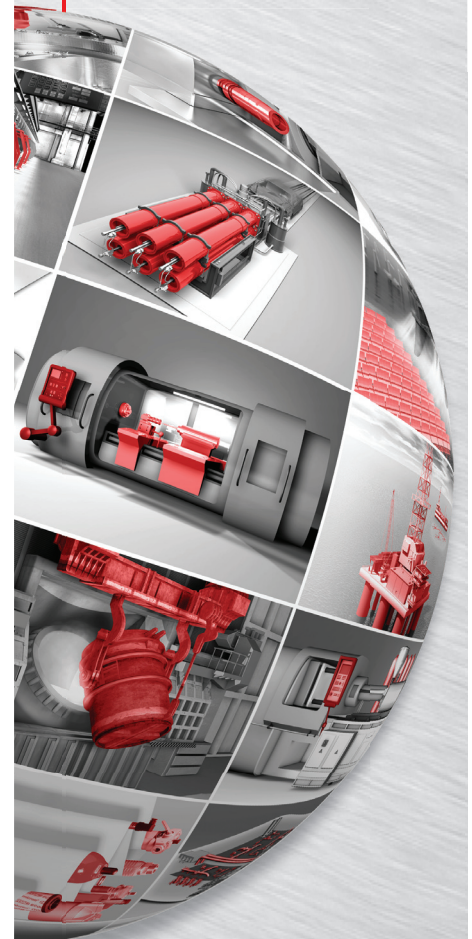

With over 7,000 employees, 45 overseas companies and over 500 sales & service partners, HYDAC is your reliable partner worldwide.

Our product range includes hydraulic accumulators, fluid filters, process filters, coolers, electrohydraulic controls, industrial valves, sensors for pressure, displacement and magnet technology, cylinders, pumps, mounting technology, hydraulic fittings, condition monitoring and much more.

We design and supply turnkey hydraulic control and drive systems including the electronic controls for mobile and stationary machines and systems for a diverse range of industries.

**HYDAC INTERNATIONAL GMBH**  
Industriegebiet  
66280 Sulzbach/Saar, Germany  
Fon: +49 6897 509-01  
Fax: +49 6897 509-577  
E-Mail: [info@hydac.com](mailto:info@hydac.com)  
Internet: [www.hydac.com](http://www.hydac.com)

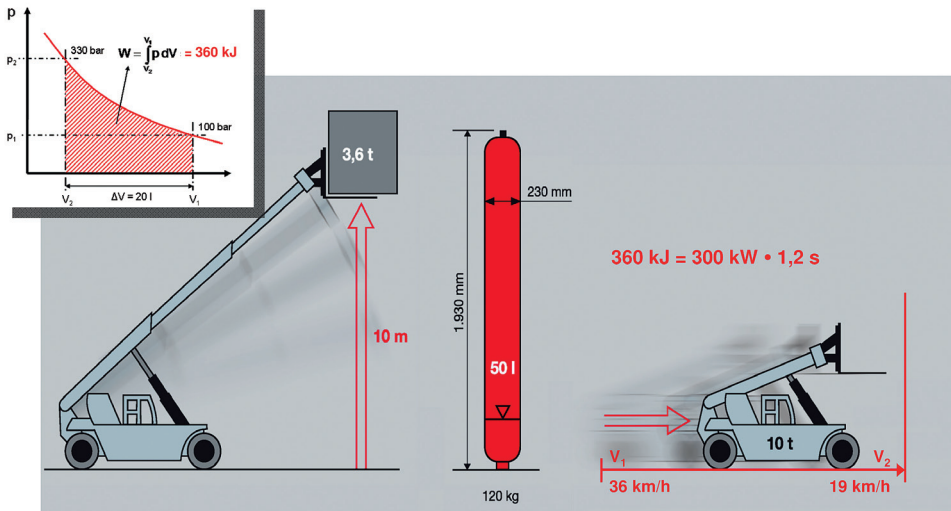

Fig. 3: Energy and efficiency of an accumulator using the example of a lifting and braking process

mulator, HYDAC is able to carry out a very detailed calculation of the system. At the same time, both the control-related drive structure of the machine and the range of applications (change of front-end attachments and working environments, different temperatures) is evaluated. Given the comprehensive range of bladder and piston accumulators in all sizes and pressure ranges, with the possibility of adding back-up nitrogen bottles, HYDAC is also expert in packaging the accumulator volume [2]. After all, it is important to package the accumulator on the machine so as not to compromise the working area or the machine operator's visibility. The last stage is to select the appropriate mounting elements or clamps to guarantee long life, robustness and safety in the finished machine. (Fig. 2).

But HYDAC accumulators excel not only in the system but also in their components because of their specific characteristics. For example, a few years ago, a special piston accumulator seal was developed for the mobile sector. Not only does it have a very

large application temperature range from -30°C...120 °C, but it is also capable of withstanding the extreme vibrations and lateral forces on the machine. Other distinguishing features are the low piston friction (just 1-2 bar) and the same high gas tightness as before. Given these characteristics, it is possible to position the piston accumulator both vertically and horizontally, close to the internal combustion engine, in the chassis area, on moving attachments and on parts of the equipment which have no protection from the climate. Using the experience HYDAC has gained from designing and producing such systems for numerous applications, and precisely because of the often very confined installation space (particularly on smaller machines), the idea came about to compensate the load directly using a gas cylinder rather than going the long way round with the „additional cylinder“. The special challenge here was to design a seal system capable of sealing the high gas pressures (up to 450 bar) on the dry piston rod. To achieve this, the sealing system has a specially created lubrication oil chamber which in turn is linked to the gas pressure chamber via a small separating accumulator. In this way the primary seal is lubricated and the pressure is compensated (equivalent to a seal in the piston accumulator). The secondary seal can be made like a conventional piston rod seal, as in the hydraulic cylinder. Thus the customer gains a gas cylinder with a tremendously high energy density coupled with the robustness of a hydraulic cylinder.

Since machine builders and their customers market their machines all over the world these days, it is important to know about the country-specific certification for accumulators as well as the technical aspects of accumulator sizing. HYDAC is well-acquainted with the certification and as a result all accumulators are sized, manufactured and documented according to the current regulations.

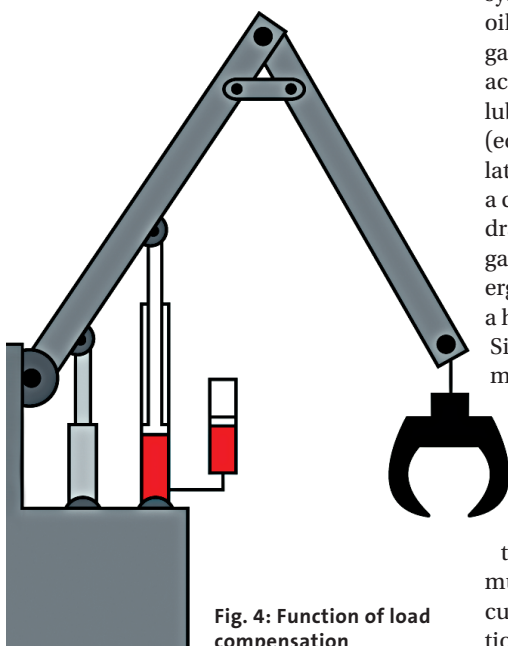

Fig. 4: Function of load compensation

### What does HYDAC offer hybrid technology?

With its wide range of accumulators and many years' experience, the HYDAC company is the ideal partner for developing and producing specific hybrid solutions. In addition to providing support in engineering (conception, accumulator sizing, packaging, validation etc) HYDAC has advanced successive individual accumulator solutions (gas cylinders, double piston accumulators [3], lightweight accumulators) to satisfy the demand for accumulators generated by hybrid technology, particularly from the cost perspective. A wide variety of accessories such as safety equipment, clamps, valves, sensors, right up to electronic controls completes the range to meet the demands of the customer (Fig. 1).

HYDAC

[www.vfmz.net/5504040](http://www.vfmz.net/5504040)

#### References

- [1] Frerichs, L., et. al.: Trends bei Bau- und Erdbewegungsmaschinen – Beobachtungen anlässlich der bauma 2013 [Trends in Construction Machinery and Earthmovers – Observations made at bauma 2013 Exhibition], O+P 6/2013, S. 17-21
- [2] Feld, D.; Kloft, P.; Groben, M.: Packaging von Hydrospeichern für Hybridanwendungen in Baumaschinen [Packaging of Accumulators for Hybrid Applications in Construction Machinery]. In: Conference Proceedings of 5th Specialist Conference on Construction Machinery Technology, Dresden, 2012, Pages 97-110
- [3] Bauer, E; Feld, D.; Grün, S.: Doppelkolbenspeicher – Innovativer Hydraulikspeicher für mobile Arbeitsmaschinen [Double Piston Accumulators – Innovative Accumulators for Mobile Machines]. In: Conference Proceedings of 3rd Specialist Conference on Hybrid Drives for Mobile Machines, Karlsruhe, 2011, Pages 137-149

### Summary

Hydraulic hybrid technology is robust, simple to handle and the cost-effective alternative.

