

GSM Radio Module CSI-F-10

User Manual

English (translation of original instructions)



Table of Contents

1	General	9
1.1	Previous Knowledge.....	9
1.2	Structure of the Manual.....	9
1.3	Copyright Protection	10
1.4	Note on Warranty	10
1.5	Declaration of Conformity 	10
2	Safety	11
2.1	General Safety Precautions	11
2.2	Antenna.....	12
2.3	Electronic Devices	12
2.4	Potentially Explosive Substances / Locations.....	12
2.5	Air travel	12
2.6	Safety-Related Applications	12
2.7	SIM card	12
2.8	Loss / Theft of the SIM card or of the Device	12
3	Proper/Designated Use	13
3.1	Stand alone operation	14
3.2	Operation as GSM modem on a CMU 1000.....	14
4	Installation	15
4.1	Unpacking.....	15
4.2	Installing the Unit.....	15
5	Setup and Function	16
5.1	Display elements / Connections	16
5.2	Pin connections	17
5.3	Connection examples for sensors	18
5.3.1	HYDACLab [®] to Connection 1 and CS 1000 to Connection 2	18
5.3.2	AS 1000 to Connection 1 and CS 1000 to Connection 2.....	19
5.3.3	HYDACLab [®] and AS 1000 to Connection 1	20
5.4	Connection to Condition Monitoring Unit CMU 1000	20
5.4	Connection to Condition Monitoring Unit CMU 1000	21
6	Commissioning	22
6.1	Insert SIM card	22
6.2	Program enable.....	23
6.3	Voltage supply with communication via direct connection with interface module CSI-B-2	24
6.3.1	Device Connection.....	25
6.3.2	Connection Setup	26

6.4	Voltage supply with communication via direct connection to Portable Data Recorder HMG 510.....	34
6.4.1	Device Connection.....	35
6.4.2	Connection Setup.....	35
6.4.2	Connection Setup.....	36
6.5	Voltage supply with communication via GSM mobile radio connection (standard application)	44
6.5.1	Device connection	45
6.5.2	Connection Setup	45
6.6	Voltage supply and communication via Condition Monitoring Unit CMU 1000 52	
6.6.1	Device Connection.....	52
6.6.2	Connection Setup	53
7	Configuration Using CMWIN PC Software.....	57
7.1	Actions.....	57
7.1.1	Display Device Status	57
7.1.2	Display Device Information	58
7.1.3	Display Measured Values	59
7.1.4	Setup	59
7.1.5	Managing Configurations.....	63
7.1.6	Set bus address.....	64
7.1.7	Managing sensor constellations	64
7.1.8	Sending a text message	65
7.2	Extras	66
7.2.1	Update Firmware	66
8	CM Editor	69
8.1	Menu Bar.....	70
8.1.1	File	70
8.1.2	CM Program	71
8.1.3	Grouping	75
8.1.4	Device.....	75
8.1.5	Sensor constellation	76
8.1.6	Extras.....	78
8.2	Window Divisions	79
8.2.1	"Function Properties" Window	79
8.2.2	"Function List" Window	79
8.2.3	"Linked Functions" Window	79
8.2.4	"Functions" Window.....	79
9	CM Program Functions.....	80
9.1	General Information Concerning Functions.....	80
9.1.1	Inputs / Outputs	80
9.1.2	Parameters	81
9.2	Data Sources	82
9.2.1	Numerical Constant	82
9.2.2	Measured value	82
9.2.3	Digital Input.....	82
9.2.4	Numerical Entry	83
9.2.5	Boolean Entry	83
9.2.6	Time Sensor	84
9.2.7	Clock Timer.....	84

9.2.8	Error Event.....	85
9.2.9	Boolean Constants	85
9.3	Numerical Calculations	86
9.3.1	Addition.....	86
9.3.2	Subtraction.....	86
9.3.3	Multiplication	86
9.3.4	Division	86
9.3.5	Division Remainder.....	87
9.3.6	Absolute Value.....	87
9.3.7	Change of Algebraic Sign	87
9.3.8	Rounding	87
9.3.9	Raising to a Higher Power	88
9.3.10	Square Root.....	88
9.3.11	Power at Base e	88
9.3.12	Natural Logarithm	88
9.3.13	Decade Logarithm	89
9.3.14	Integral.....	89
9.3.15	Differential Quotient.....	90
9.4	Numerical Operations.....	91
9.4.1	Minimum	91
9.4.2	Maximum	91
9.4.3	Limit	91
9.4.4	If - then - else.....	91
9.4.5	Median Value.....	92
9.4.6	Note Value	92
9.4.7	Note Minimum.....	92
9.4.8	Note Maximum.....	93
9.4.9	Tabular Value	93
9.4.10	Tabular Index.....	94
9.4.11	Characteristic Curve	94
9.4.12	Ramp	95
9.5	Counting Functions	96
9.5.1	Count Pulses	96
9.5.2	Stop Watch	96
9.6	Numerical Conditions.....	97
9.6.1	Equals.....	97
9.6.2	Does not Equal	97
9.6.3	Greater than.....	98
9.6.4	Greater than or Equal to	98
9.6.5	Less than	98
9.6.6	Less than or Equal to.....	99
9.6.7	Within.....	99
9.6.8	Outside	99
9.7	Boolean Links	100
9.7.1	Not	100
9.7.2	And	100
9.7.3	Not - And.....	100
9.7.4	Or.....	101
9.7.5	Not - Or.....	101
9.7.6	Exclusive Or.....	102
9.7.7	Not Exclusive Or	102
9.8	Other Boolean Operations	103
9.8.1	Note Switching Status.....	103

9.8.2	Switching Delay	103
9.8.3	T - Flipflop.....	104
9.8.4	Mono Flop.....	104
9.8.5	RS - Flipflop	105
9.8.6	Pulse Generation	105
9.9	Result Values	106
9.9.1	Numerical Output Value.....	106
9.9.2	Boolean Output Value.....	107
9.10	Actions.....	108
9.10.1	Setting Switching Output	108
9.10.2	Switch on LED	108
9.10.3	Send SMS.....	108
9.11	Other	109
9.11.1	Comment	109
10	Error Messages CM Program Compilation.....	110
10.1	Overriding Error Messages.....	111
10.1.1	Function not Available in this Mode.....	111
10.2	Error Messages with Data Sources.....	111
10.2.1	Invalid Channel Setting.....	111
10.2.2	Duplicate Channel Name.....	111
10.2.3	Invalid Digital Input	111
10.2.4	Duplicate Digital Input.....	111
10.2.5	Too many Boolean Input Fields	111
10.2.6	No Inscription for Boolean Input	111
10.2.7	Duplicate Inscription for Boolean Inputs	111
10.2.8	Too Many Numerical Input Values.....	111
10.2.9	No Inscription for Numerical Input	112
10.2.10	Duplicate Inscription for Numerical Input	112
10.2.11	Duplicate Error Source.....	112
10.3	Error Messages for Operations/Conditions.....	112
10.3.1	Upper and Lower Measured Value Limits too Close to one another	112
10.3.2	Measured Value Limits Outside the Range of -30000 to 30000	112
10.3.3	Lower Measured Value Limit Greater than Upper Measurement Value Limit.....	112
10.4	Error Messages with Result Values/Actions	112
10.4.1	Invalid Output LED Selected.....	112
10.4.2	Duplicate Use of Output LED.....	112
10.4.3	Invalid Digital Output.....	113
10.4.4	Duplicate Digital Output.....	113
10.4.5	Too Many Boolean Output Fields	113
10.4.6	Duplicate Boolean Output Field	113
10.4.7	The Bit Number Must Be a Figure between 0 and 14.....	113
10.4.8	Too Many Numerical Output Fields	113
10.4.9	Duplicate Numerical Output Field	113
10.4.10	Message and telephone number too long.....	113
11	Specifications	114
11.1	Power Supply	114
11.2	Sensor Inputs (5 pole female connection "Sensor 1", 8 pole female connection "Sensor 2").....	114
11.3	Logic measurement channels	114

11.4 Digital Inputs and Outputs (8 pole female connection "In/Out")..... 114

11.5 Interfaces 114

11.6 Cycle Time 115

11.7 Operating and Ambient Conditions 115

11.8 Dimensions and Weight: 115

11.9 Technical Standards..... 115

11.10 Items supplied 115

11.11 Maintenance and cleaning..... 115

11.12 Recycling and Disposal 116

12 Ordering Details..... 117

13 Exclusion of liability..... 117

14 Accessories 118

Preface

We have compiled the most important instructions for the **operation** and **maintenance** of our product for you, its user, in this documentation.

It will acquaint you with the product and assist you in using it as intended in an optimal manner.

Keep it in the vicinity of the product so it is always available.

Note that the information on the unit's engineering contained in the documentation was that available at the time of publication. There may be deviations in technical details, figures, and dimensions as a result.

If you discover errors while reading the documentation or have additional suggestions or notes, contact us at:

HYDAC ELECTRONIC GMBH
Technical Documentation
Hauptstraße 27
66128 Saarbrücken
-Germany-
Tel: +49(0)6897 / 509-01
Fax: +49(0)6897 / 509-1726
Email: electronic@hydac.com

The editorial board would welcome your contributions.

„Putting experience into practice“

1 General

This manual is a constituent part of the device. It contains texts and graphics concerning the correct handling of the product and must be read before installation, assembly and the operation of the device.

The manual offers information concerning the safe operation, installation and programming of the GSM radio module CSI-F-10. It is aimed at engineers, programmers, fitters and maintenance personnel with a general knowledge of automation technology.

By using this manual as recommended, you will ensure that the CSI-F-10 is put into effective and safe operation as quickly as possible. The following questions are covered in the next few points:

- What prior knowledge must one have in order to be able to program the CSI-F-10?
- How is this manual structured?
- What's the best way to use this manual?
- What information can I find in this manual?

1.1 Previous Knowledge

No special previous knowledge is required for using and programming the CSI-F-10 GSM radio module.

A general knowledge of automation technology or memory-programmable controllers and a knowledge of control technology or PLC programming will however be advantageous and speed up the familiarization period.

1.2 Structure of the Manual

We have integrated a variety of different Help functions to make it easier to use this manual. Please consult the Table of Contents to find a specific topic. A brief overview is provided at the beginning of each Chapter listing the contents of that particular Chapter.

Selective Reading

You will find notes in the side margins that make it easier to find particular sections. Pictograms and markings are also given, and these are explained below.

Furthermore, this manual also contains instructions regarding personal safety and the avoidance of property damage that must be observed. The instructions are highlighted by a Warning symbol and displayed as follows, depending on the seriousness of the hazard:

**Danger**

means that death, severe bodily injury or considerable property damage will occur if the respective precautionary measures are not implemented.

**Warning**

means that death, severe bodily injury or considerable property damage could occur if the respective precautionary measures are not implemented.

**Caution**

means that some non-severe bodily injury or property damage could occur if the respective precautionary measures are not implemented.

**Attention**

means that an unwanted event or condition could occur if the respective instruction is not followed.

**Note**

means an important piece of information about the product, its handling or a part of the documentation to which particular attention should be paid.

In the event that several hazard levels occur simultaneously, it is always the highest level warning notice that is used. If the warning triangle warns against possible personal injury, then a warning against possible property damage can also be attached to the same warning notice.

1.3 Copyright Protection

The dissemination and/or reproduction of this document, as well as the exploitation and communication of its content, is not permitted unless specifically authorized. Contraventions are liable to compensation. All rights reserved.

1.4 Note on Warranty

This manual was compiled with the greatest possible care. Nevertheless, errors or deviations cannot be excluded, and for this reason we assume no responsibility for the complete accuracy of the content.

In view of the fact that, despite intensive endeavors, errors can never be completely avoided, we welcome tips and suggestions for improvement at any time.

1.5 Declaration of Conformity

This product is labelled with the CE Marking and thus is in compliance with current German marketing authorization regulations and European standards. As a consequence, compliance with the current regulations on electromagnetic compatibility and the safety provisions of the Low-Voltage Directive is ensured.

This product complies with the provisions of the following European Directives: EN 61000-6-1 / 2 / 3 / 4 and the R&TTE Directive 1999/5/EC.

2 Safety

2.1 General Safety Precautions

Follow the specifications contained in this description. Non-observance of the instructions, operation in applications other than those outlined below, incorrect installation/assembly or incorrect handling of the product can be severely detrimental to the safety of personnel and systems/machines and will invalidate warranty and liability claims.

Immediately after unpacking, check that all items have been supplied correctly and that the device is in perfect condition.

The device may not be commissioned or operated except by qualified personnel who can be regarded as being "competent" as defined in the EMC and Low Voltage Directives.

Qualified personnel are individuals who are authorized to operate, ground and label devices, systems and electrical circuits in accordance with safety standards.

All relevant and generally recognized safety requirements must be complied with.

If the voltage supply to the device is not provided by an on-board electrical system (24 V battery operation), then care must be taken to ensure that the external voltage is generated and routed in accordance with the criteria for safe low voltage (SELV [Separated Extra Low Voltage] pursuant to EN 60950), in view of the fact that this is available for supplying the connected control system, sensor system and actuating elements without any other additional measures being implemented.

The wiring of all of the signals connected with the SELV circuit in the device must also meet the SELV criteria (safe extra low voltage with protective separation from other electrical circuits).

If the SELV voltage supplied is grounded externally (PELV according to EN 50178), then responsibility for this and for compliance with any applicable national installation regulations rests with the operator.

All of the statements made in this manual refer to devices which are not grounded in terms of the SELV voltage.

Generally speaking, DIN VDE 0100 Part 410 must be observed for the supply voltage.

Only the particular signals which are specified in the Technical Data and/or on the device label may be supplied to the connections and only authorized HYDAC ELECTRONIC GMBH accessory components may be connected to them.

In accordance with the following technical specifications, the device can be operated in a wide range of ambient temperatures. Due to the additional self-heating of the device, high contact temperatures may develop on the housing in hot environments.

In the event of faults or if anything is unclear, please contact your nearest HYDAC representative. Tampering with the unit can have severe consequences for personal and system safety. These are not permitted and will invalidate all liability and warranty claims.

Fault investigation and repairs may only be carried out by HYDAC SERVICE GMBH Customer Service Department.

2.2 Antenna

Operating the radio module without attaching the antenna or when the antenna is faulty, can damage the unit.

2.3 Electronic Devices

Operating the CSI-F-10 can under certain circumstances adversely affect the functioning of other electronic devices if they are not screened correctly.

Please contact the manufacturer of the particular device in the event of failure.

Do not operate the GSM radio module CSI-F-10 in the vicinity of medical equipment!

2.4 Potentially Explosive Substances / Locations

The radio modules in the series CSI-F-10 may not be operated in the vicinity of fuel stations, fuel depots, chemical plants or blasting work.

When operated in off-highway vehicles, construction, agricultural or other machinery, no flammable gases, fluids or other explosive substances may be transported or stored in the parts of the vehicles in which the radio module is mounted.

2.5 Air travel

The GSM radio module CSI-F-10 must not be operated on board aeroplanes, helicopters or other aircraft.

Operation in one of the above-mentioned aircraft, would adversely affect the navigation, control and / or communication systems.

Contraventions can result in legal proceedings against offenders.

2.6 Safety-Related Applications

Do not install the GSM radio module CSI-F-10 for safety-related applications (to DIN EN ISO 13849-1 Functional Safety).

2.7 SIM card

Please note that a SIM card is required to operate each CSI-F-10. You can obtain SIM cards from the usual providers, such as T-Mobile, VODAFONE or E-Plus.

Deactivate the mailbox function and the caller ID restriction.

2.8 Loss / Theft of the SIM card or of the Device

In order to prevent fraudulent use, inform your network operator immediately if the SIM card or the radio module is lost or stolen.

3 Proper/Designated Use

The GSM radio module CSI-F-10 is an electronic unit with universal application for transferring data and digital signals via the GSM mobile radio network. The device can be used in both stand-alone operation and as a GSM modem on a CMU 1000 (*HYDAC Condition Monitoring Unit*).

A maximum of two HYDAC SMART sensors with HSI interface (automatic sensor recognition), e.g. HYDACLab[®], AS 1000 or CS 1000, can be connected to its input connections.

In addition, several other system statuses can be monitored via the four integral digital inputs and transmitted in binary using the two integral digital outputs. The device can also access the machine / system being monitored directly via these digital outputs.

The sensor values, statuses etc can be requested by SMS/text. To do this an SMS with the text "Values" must be sent to the CSI-F-10. The device then automatically sends one or several reply text messages containing all the sensor values and additional information available.

**Note!**

The GSM radio module CSI-F-10 only replies or accepts data connections if the telephone number of the sender is visible and has been registered in the authorized telephone numbers in the CSI-F-10 (see Chap. 7.1.4).

The CSI-F-10 devices are designed for use in difficult conditions. They are therefore suitable for direct installation in machines and systems and in stationary and mobile off-highway applications (not for public road and rail transport!).

The inputs and outputs are designed to a special specification for such applications. Integrated hardware and software functions (operating system) provide a greater level of protection for the machine.

Examples of possible applications:

- Remote parameterization of HYDAC Condition Monitoring units and sensors in stationary or mobile machines and systems
- Remote diagnostics of system conditions
- Transmission of alarm messages as SMS
- Read-outs of operating conditions from machines that are running
- ...

**Warning!**

The device may be used only for the types of applications specified in the manual and only in connection with accessory components authorized by HYDAC ELECTRONIC GMBH. The trouble-free and safe operation of the product is contingent on proper transport; storage, setup and installation; and on careful operation and maintenance.

The two basic operating modes available for using the GSM radio module CSI-F-10 are described below:

3.1 Stand alone operation

The CSI-F-10 transmits the measured values and additional information of the connected sensors directly and without processing them (**passive mode**) or monitors and processes the input signals with a "CM program" stored in the unit (**active mode**).

The application software for the active mode, das "CM Program", can be readily generated by the user using the "CM Editor" on a PC. The "CM Editor" is a component part of the HYDAC PC software "CMWIN", version 3.0 or higher.

In the above-mentioned "CM program" you define in detail which data will be monitored and how, and when and which type of message should occur.

For example, once a parameterized limit has been exceeded, an alarm SMS can be sent or a switch output can be set. All texts and telephone numbers for the relevant SMS must be stored in the CM program by the user.



Note!

All of the programming procedures and software functions subsequently described in this documentation refer to the "CM Editor" in accordance with IEC 61131.

The operator is responsible for the safe and application-appropriate functioning of the CM Programs that he or she generates.

3.2 Operation as GSM modem on a CMU 1000

When using the unit as a GSM modem, the CSI-F-10 must be connected via HSI signal (HYDAC sensor interface) to the CMU 1000. The CMU 1000 is in this case the "bus master" and controls the radio module.

In this operating mode, one or more sensors are monitored by the CMU 1000. Their input signals are evaluated according to the CM program stored in the CMU 1000 and processed.

The resulting data and / or messages are transmitted from the CMU 1000 via HSI interface to the GSM radio module. The radio module transfers this data and / or messages controlled by the CMU 1000 directly by SMS.

The SMS text and the receiving telephone number are stored in the CM program in the CMU 1000 for this purpose.

4 Installation

4.1 Unpacking

The CSI-F-10 is supplied in a cardboard box. When taking delivery and when unpacking the unit, check it for transit damage and report any damage to the carrier immediately.

4.2 Installing the Unit

Only fit the unit in locations where the radio module can be operated without risk (see Chapter 2. Safety).

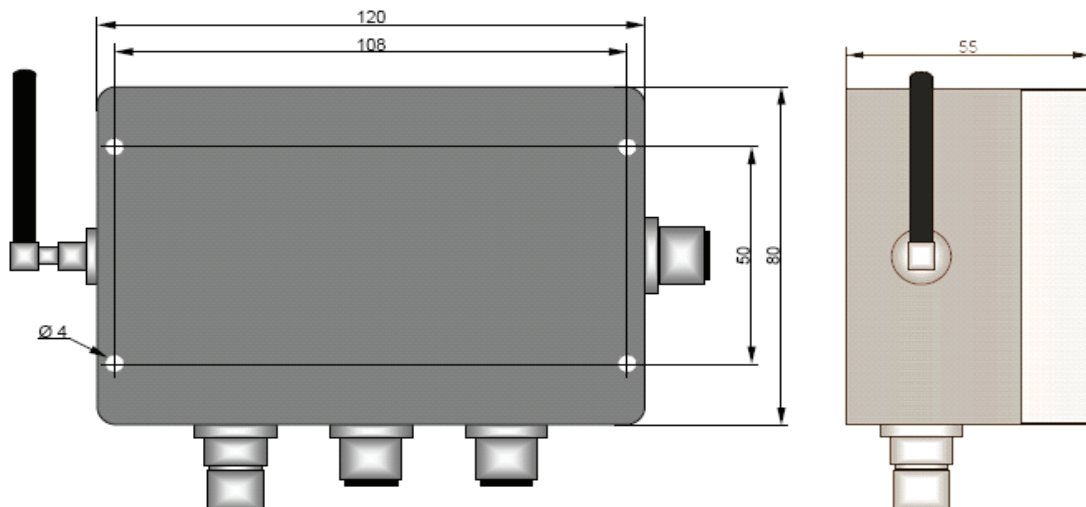

- When you are planning the layout for your system, allow sufficient space underneath the unit and to the right of the unit, and distance between it and other devices for cabling the peripherals and for connecting the communication cable.
- Mount the GSM radio module using the mounting holes provided in the lower part of the housing. To do this, the housing cover of the radio module must be removed.
- When installing in off-highway vehicles, construction & agricultural machinery etc, avoid placing near to fuel tanks, tanks containing explosive substances or electronic components which are inadequately screened.
- Do not fit the antenna in enclosed metal constructions, such as a driver's console or cab, or similar (Faraday screening effect).
- Do not lengthen or shorten any antenna lines.

Note!



The condition for a stable GSM mobile radio connection is a good antenna signal. If problems occur, change the position of the antenna or the mobile device. Also, if the antenna plug is not tightly fitted this will cause a loss of signal! The antenna connection must be protected from humidity and moisture.

5 Setup and Function

The GSM radio module CSI-F-10 is an electronic device with universal applications for transmitting data and digital signals over the GSM mobile radio network. A maximum of two HYDAC SMART sensors with HSI interface (automatic sensor recognition), e.g. HYDACLab®, AS 1000 or CS 1000, can be connected to its input connections.

5.1 Display elements / Connections

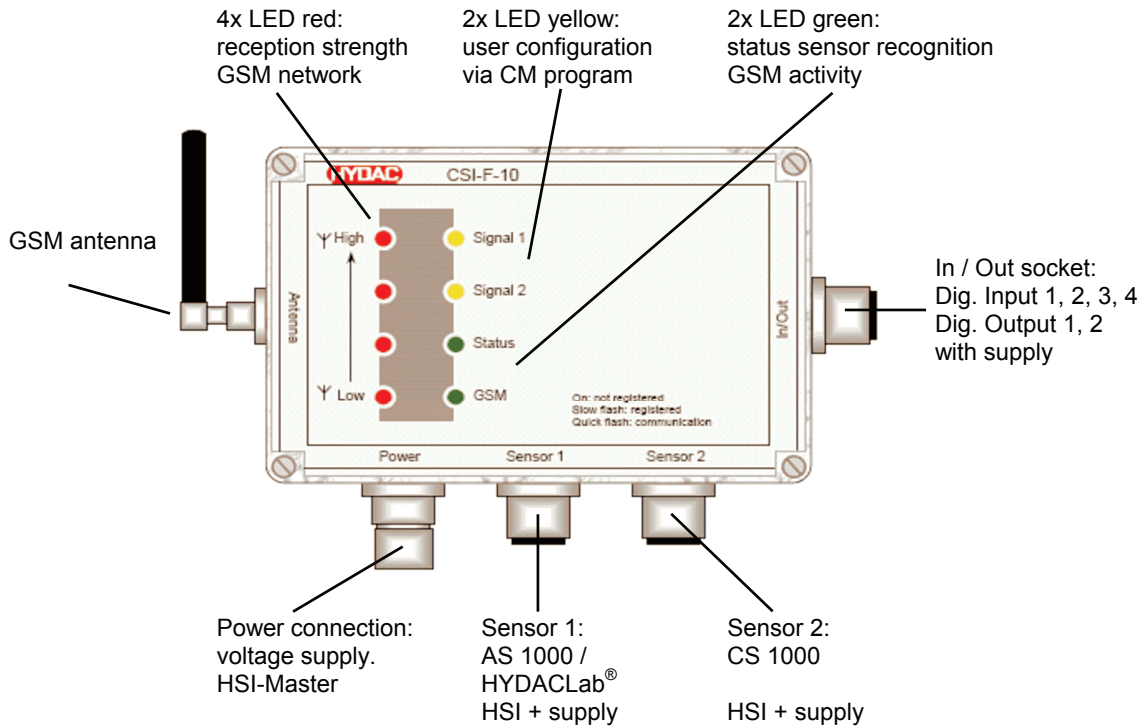

LED	Color	Condition	Meaning
High ↑ Low	red	On	4 LEDs: reception strength > 75 % 3 LEDs: reception strength > 50 % 2 LEDs: reception strength > 25 % 1 LED: reception strength < 25 %
		All Off	No reception
GSM	green	On	Not registered
		Rapid flashing	Communication
		Slow flashing	Registered
Status	green	On	Min. 1 sensor recognised
		Flashing	PC connection active
		Off	No sensor recognised
Signal 1	yellow	On / Off	Function according to CM program (programmable user application)
Signal 2	yellow	On / Off	

In the initialization phase (approx. 10 sec.) the LEDs will not indicate any defined condition.

5.2 Pin connections

Plug	Pin	Function	I/O
Power	1	+U _B (in)	
	2	n.c.	
	3	0 V	
	4	n.c.	
	5	HSI	

Plug	Pin	Function	I/O
Sensor 1 (AS 1000 HLB 1000)	1	+U _B (out)	
	2	n.c.	
	3	n.c.	
	4	0 V	
	5	HSI	IN / OUT

Plug	Pin	Function	I/O
Sensor 2 (CS 1000)	1	+U _B (out)	
	2	n.c.	
	3	0 V	
	4	n.c.	
	5	HSI	IN / OUT
	6	n.c.	
	7	n.c.	
	8	n.c.	

Plug	Pin	Function	I/O
In / Out	1	Digital Out 1	OUT
	2	Digital In 1	IN
	3	+U _B (out)	
	4	Digital In 2	IN
	5	0 V	
	6	Digital In 3	IN
	7	Digital In 4	IN
	8	Digital Out 2	OUT

5.3 Connection examples for sensors



Warning!

The total length of the connected sensor cables (Sensor 1 + Sensor 2) may not exceed max. 40 m. If this 40 m length is exceeded, there can be problems with the HSI signal transmission.

5.3.1 HYDACLab[®] to Connection 1 and CS 1000 to Connection 2

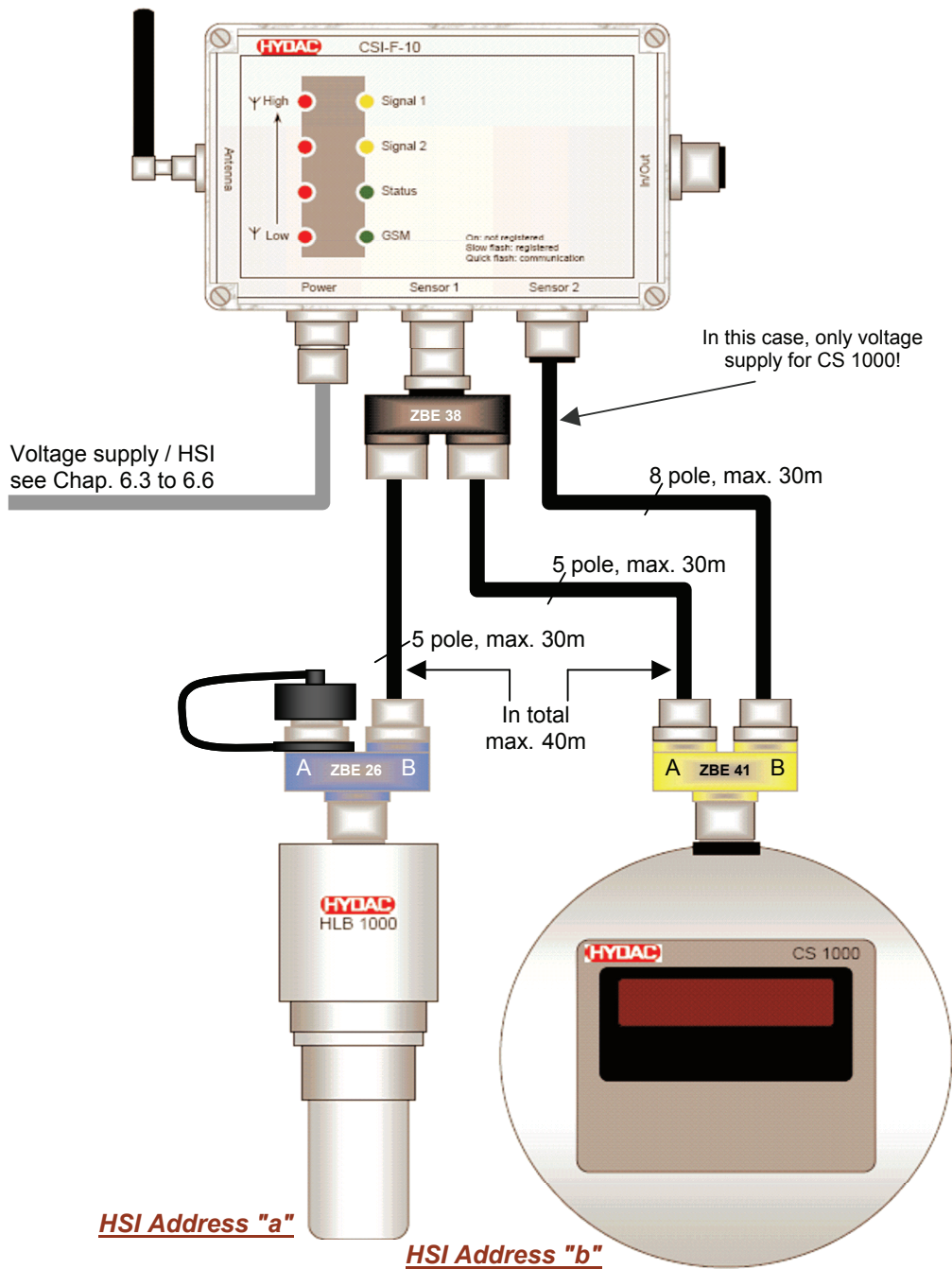

Note!

Connection "A" of the ZBE 26 (blue Y adaptor) must be sealed using the protective cap provided, to protect it from dirt and moisture!

5.3.2 AS 1000 to Connection 1 and CS 1000 to Connection 2

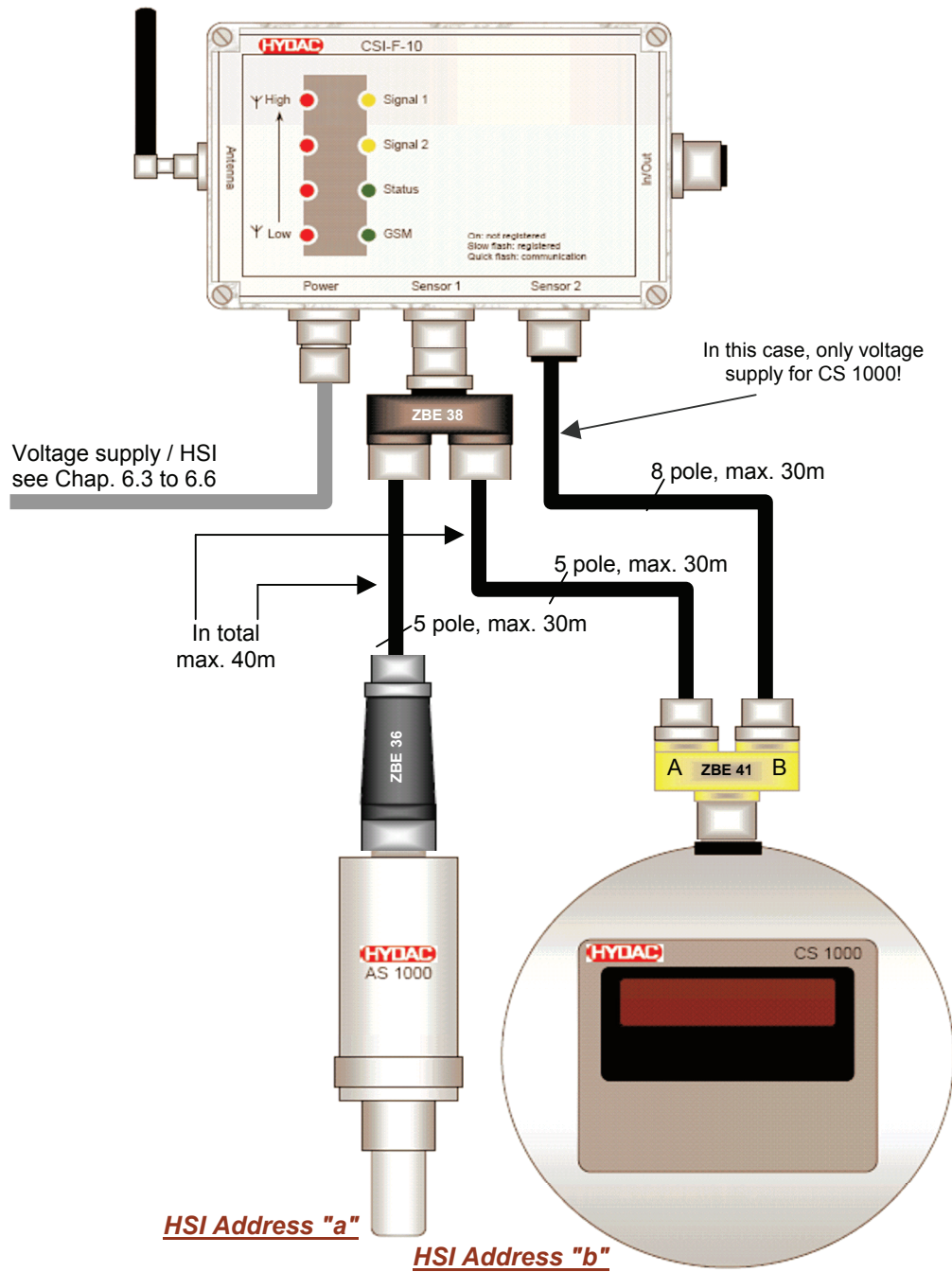

5.3.3 HYDACLab[®] and AS 1000 to Connection 1

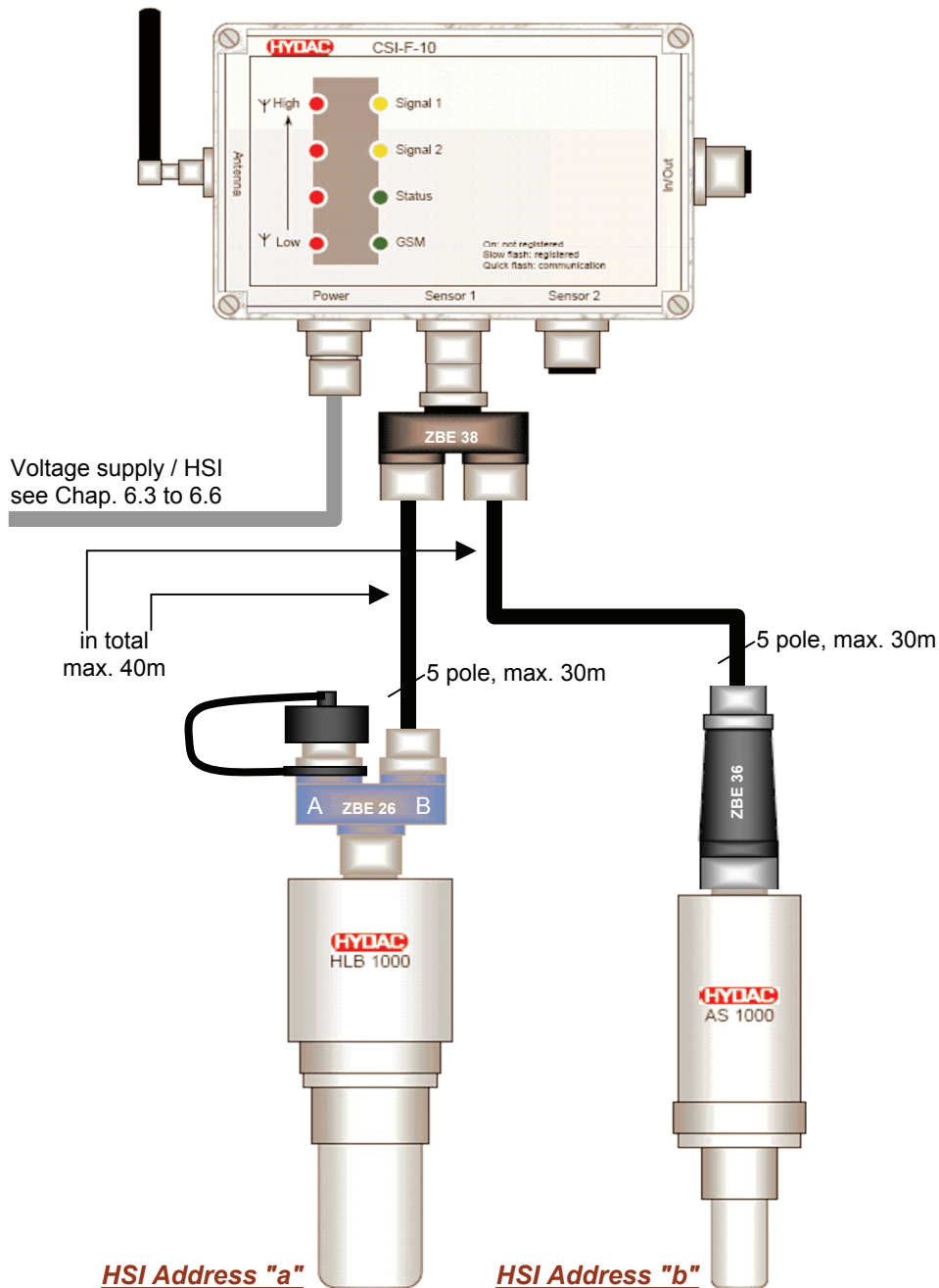

Note!



Regardless of the type of constellation, a maximum of 2 SMART sensors can be connected to the CSI-F-10 and evaluated by the device. The connected sensors must already be addressed using the HSI addresses "a" and "b". In other words, each sensor must be addressed before connecting to the CSI-F-10, for example using an HMG 3000.

5.4

Connection to Condition Monitoring Unit CMU 1000

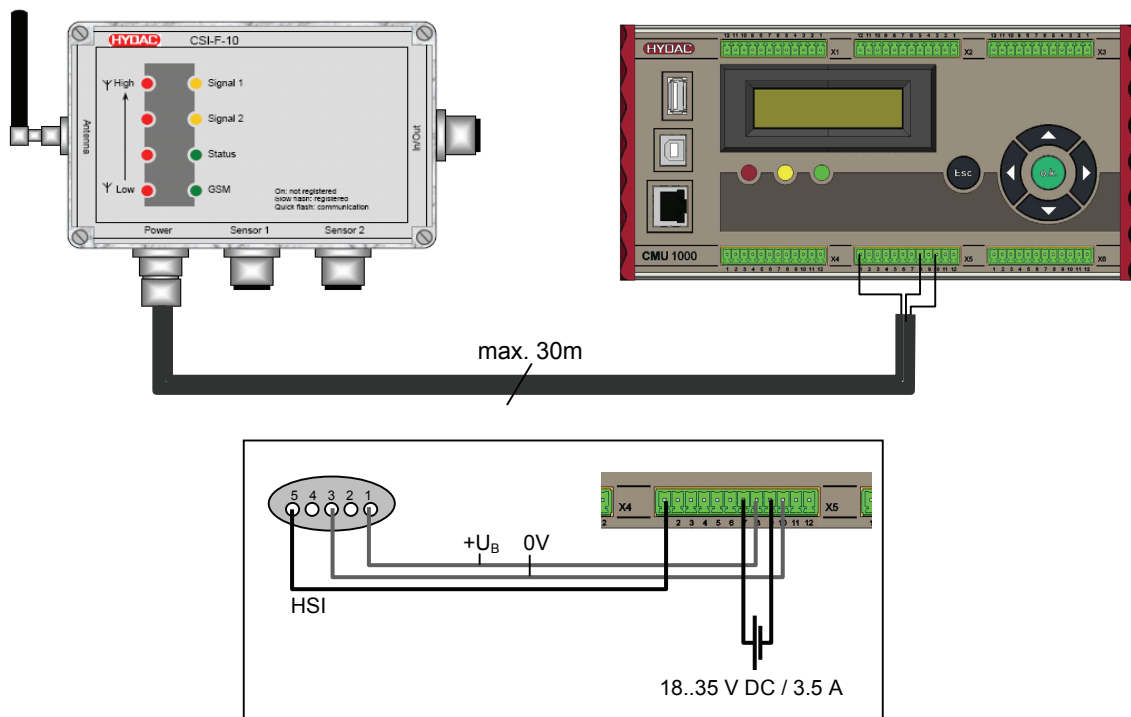

Note!



For this connection option, the CMU 1000 can either be configured via the CSI-F-10, or the CSI-F-10 can be configured via the CMU 1000. In addition the CSI-F-10 acts as the GSM modem to the CMU 1000, to forward data and / or messages sent from this unit (see Chap. 3.2.). Similar to the SMART sensors, the CMU 1000 must also be addressed with an HSI address ("a" or "b") before connecting to the CSI-F-10.

6 Commissioning



Note!

In order to be able to communicate later with the CSI-F-10 via GSM mobile radio, this must first be configured. This means that the mobile phone numbers which are authorized for access must be stored in the CSI-F-10 and appropriate permissions assigned. In order to configure the GSM radio module CSI-F-10, first connect directly with the GSM radio module CSI-F-10 (via CSI-B-2, HMG 510 or CMU 1000).

► See Chapter 6.3, 6.4 and 6.5!

6.1 Insert SIM card



Warning!

Only ever insert or remove the SIM card when voltage supply is disconnected.

- Remove the housing cover by unscrewing the 4 mounting screws.
- Press on the catch "PUSH OPEN" and lift the SIM card holder to the right.
- Push the SIM card into the holder as per the diagram.

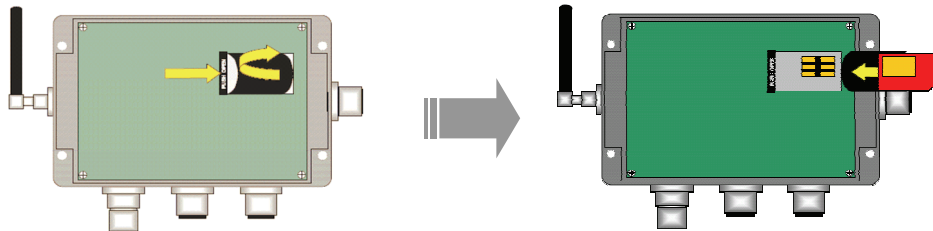

- Lift the holder again to the left, until it snaps back into the catch

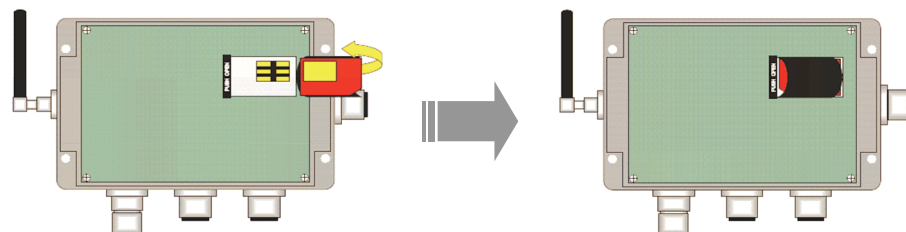

- Replace the housing cover back onto the lower part of the housing.

The GSM radio module CSI-F-10 can only operate as such with a valid SIM card. This card and the pin number for it can be obtained from your network operator or GSM service provider.

For the direct transfer of data (online mode) you will need a SIM card which supports the GSM data service and which is enabled for this.

(The GSM data service is not available in all countries and is not supported by all mobile phone operators. Please contact your service provider for further information. This information does not apply to text messages!)



Use of pre-paid SIM cards!

Pre-paid SIM cards have a limited validity and limited credit. If the credit is used up or the validity has expired, the function of the GSM radio module will no longer be guaranteed!

► Top up your pre-paid SIM card in good time!



Warning!

SIM cards and their contacts can easily be damaged by scratching or bending. When handling the card, avoid placing any force on or touching the contacts.

***PIN deactivation***

If the PIN number is not input correctly or in full, during commissioning the SIM card can be blocked.

We recommend therefore that the PIN of the SIM card is deactivated. To deactivate the PIN code, place the SIM card in a mobile telephone and follow the device menu to deactivate the PIN request.

***Deactivating call forwarding / mailbox***

Deactivate all the call forwards and the mailbox functions of the SIM card to be used to achieve efficient accessibility with the CSI-F-10 GSM radio module.

6.2 Program enable

Program enable is effected via a micro-switch on the upper right edge of the board. Providing the switch is set to ON you can configure the CSI-F-10, make settings, transfer CM programs etc via a PC connection, irrespective of the permissions specified in the settings (see Chapter 7.1.4).

- Remove the housing cover.
- Push the switch to the right to "**ON**" to switch on the program enable.
- Push the switch to the left to "**OFF**" to switch off the program enable.

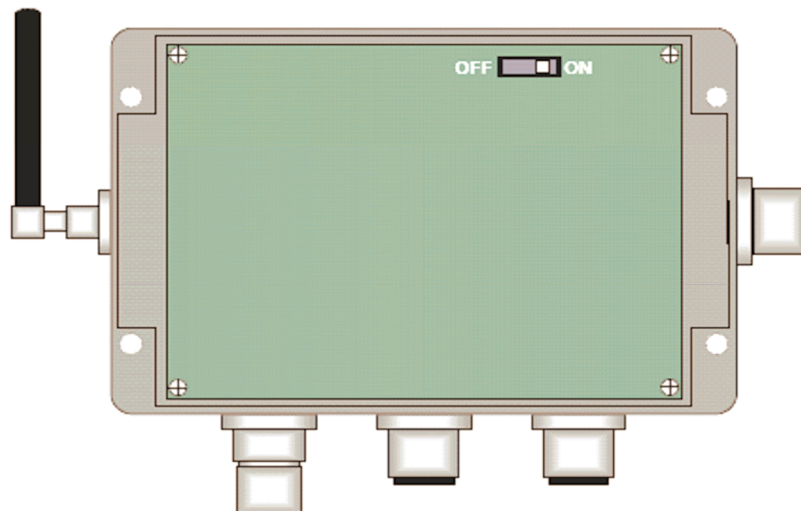
***Warning!***

When the programming enable is switched off (switch set to 'OFF') no settings, program changes or other changes to the device configuration can be made via a PC connection.

6.3 Voltage supply with communication via direct connection with interface module CSI-B-2

If a GSM radio module is connected to the PC via an adaptor such as the HYDAC interface module CSI-B-2, then the GSM radio module has the HSI address "*Bus master*".

If further sensors are connected to the CSI-F-10, these must be addressed with the normal HSI address "a" or "b".

In order to be able to communicate with the GSM radio module or with the sensors connected to it, the CSI-F-10 must first be addressed using the HSI address "*bus master*". This means the GSM modem is switched into *Slave mode* and the PC works as the bus master.

If afterwards a sensor connected to the CSI-F-10 is to be addressed, the connection between PC and GSM radio module must be disconnected. In CMWIN a query appears asking whether the master which was previously connected to the slave (the CSI-F-10) should again be the master. This query must be answered with "*No*".

After this, the connection to the sensors which are connected to the CSI-F-10 can be set up using the usual HSI addresses "a" or "b".

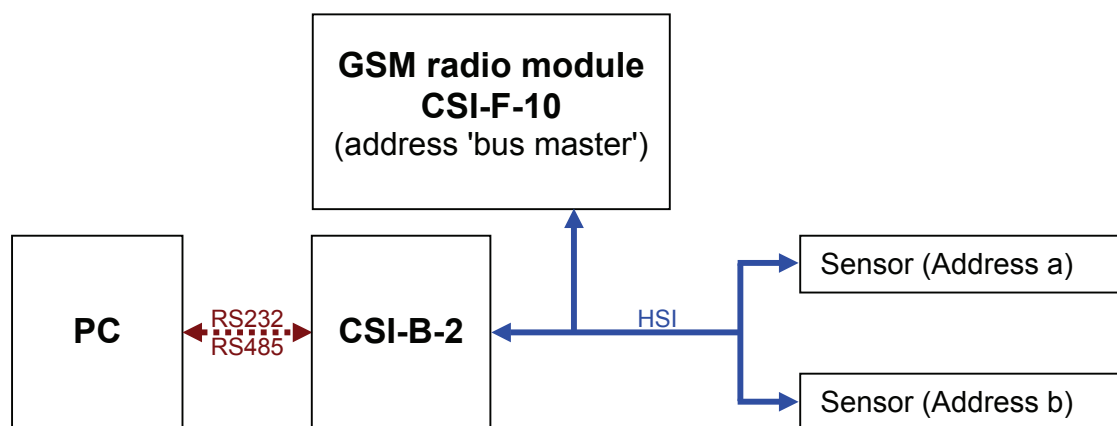

Warning!

If the GSM radio module is directly connected to the PC and CMWIN via the HYDAC interface module CSI-B-2 via HSI, no measured values are output and no new sensors will be recognized.

In other words, if a sensor had been connected to the GSM radio module before the connection setup, only those measured values which have been output directly prior to the connection setup appear in CMWIN.

Furthermore, new sensors must be connected to the CSI-F-10 before the connection setup because otherwise they will not be recognized.



6.3.1 Device Connection

- Connect the RS232 serial interface of your PC with the 9-pin SUB-D socket of the HYDAC interface module CSI-B-2 via a corresponding data cable (or RS485 via terminal block).
- Connect the CSI-F-10 to the CSI-B-2 via the HSI connection
 - -X2 / Pin 3 and 4 on the CSI-B-2
 - Connection B / Pin 4 and 5 on ZBE 26 on the CSI-F-10
- Connect the voltage supply to the CSI-F-10 GSM radio module according to the diagram.

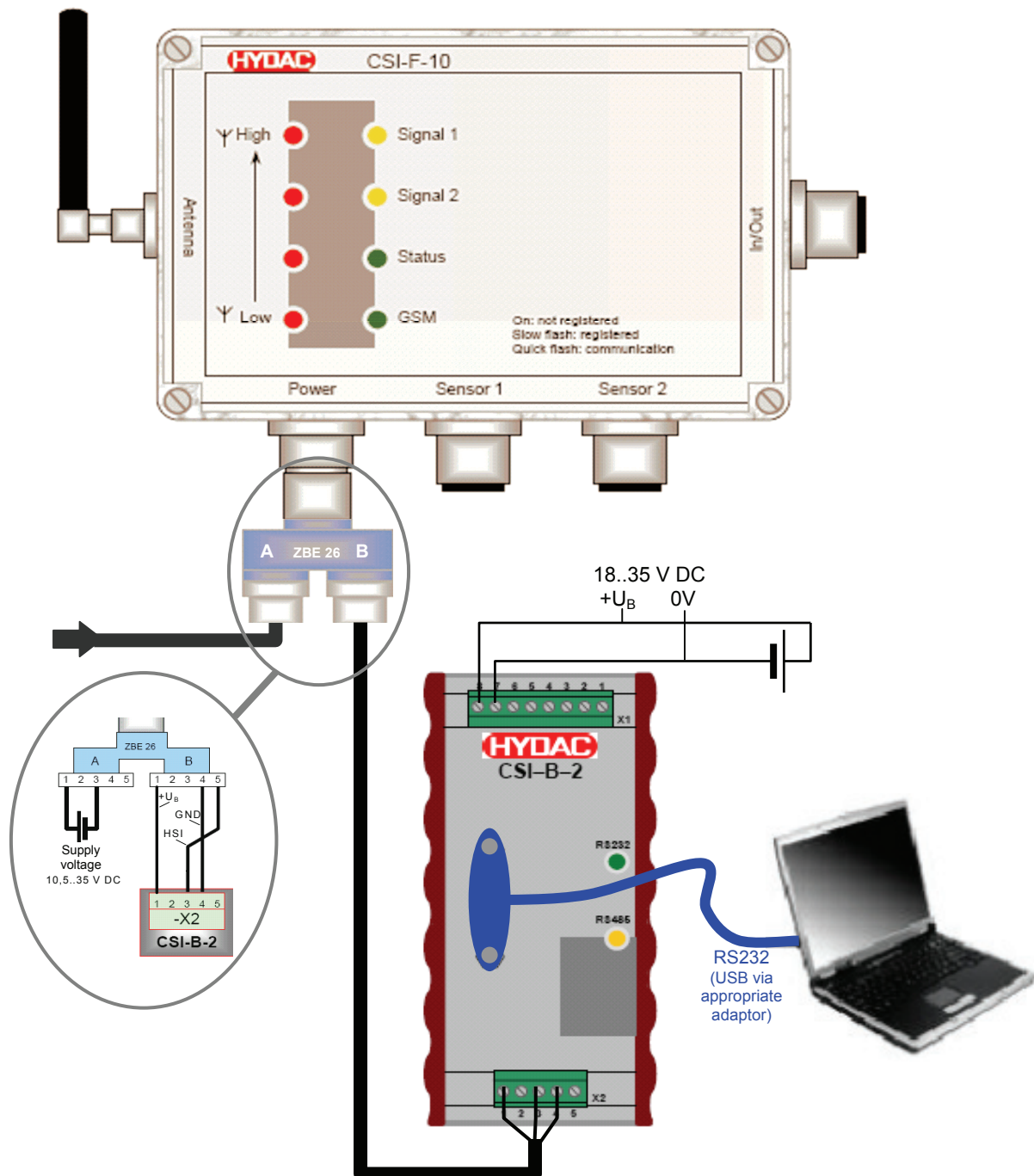

6.3.2 Connection Setup

- Start the HYDAC PC software **CMWIN**
- In the **Units** Menu, select the "**CM Manager**" option.



- If the **Connection** window does not open automatically, select "**Connection**" in the menu bar of the CM Manager.
- Select the option "**Direct connection**" in the window that opens.
- Click on "**Change**" in the top line to open the window for the interface settings.

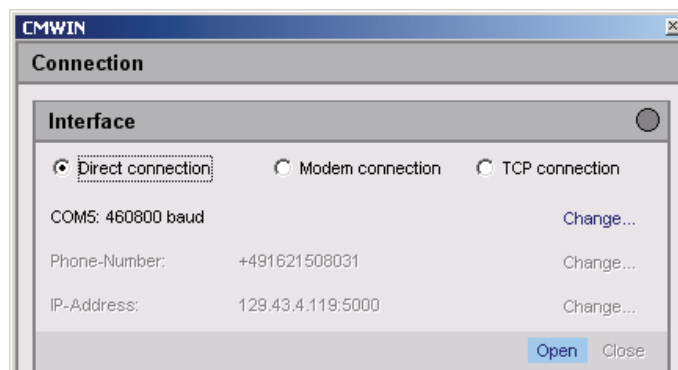

- Make the corresponding preselection for the port settings in the window that opens under **Interface selection**.
- Select the relevant port address and Baud rate under Interface settings. (9600 für CSI-B-2) aus.
- Click "**Refresh**" to update the interfaces marked under **Interface selection** in terms of availability.
- Click on "**OK**" to apply the modified settings or "**Cancel**" to discard these changes. In either case you will then return to the **Connection** window.

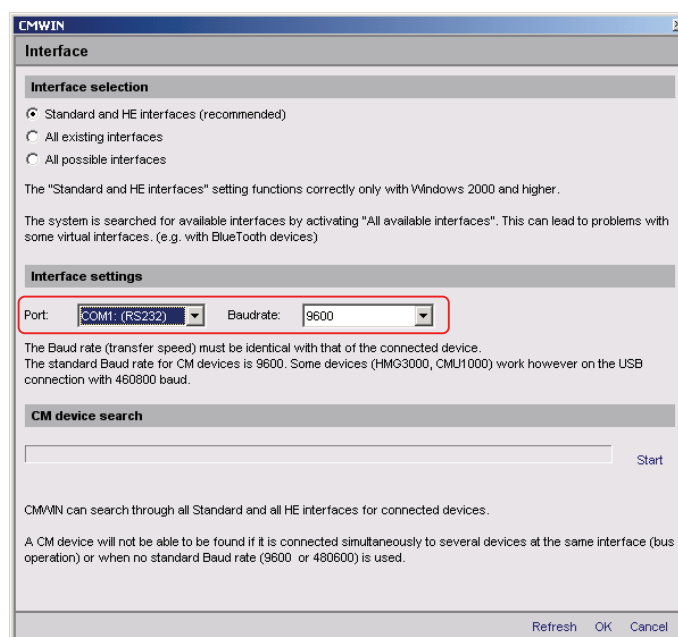

- In the **Interface** field, select the option "**Open**" in order to open the selected interface (COM port).
The opened interface will be indicated by a green dot on the right-hand edge of the window.

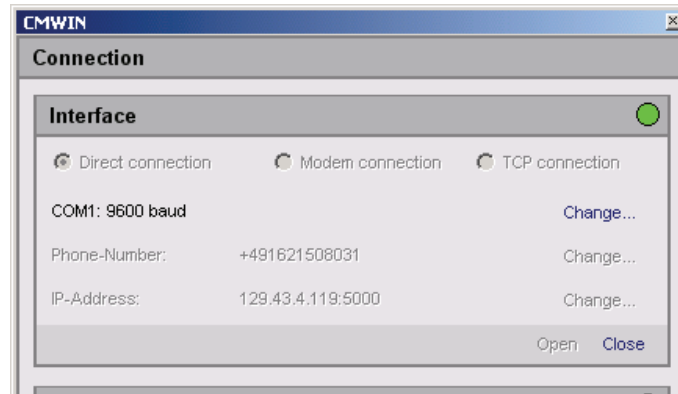

- In the **Sensor** field, specify whether you would like to connect to CSI-F-10 GSM radio module direct or to one of the sensors connected to it. Afterwards, proceed according to the three options described below.

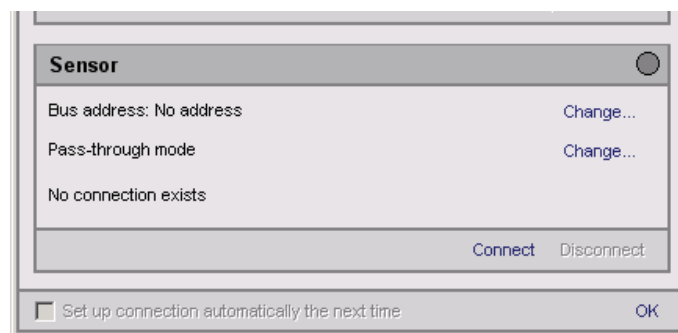

Schematic diagram of the connections!

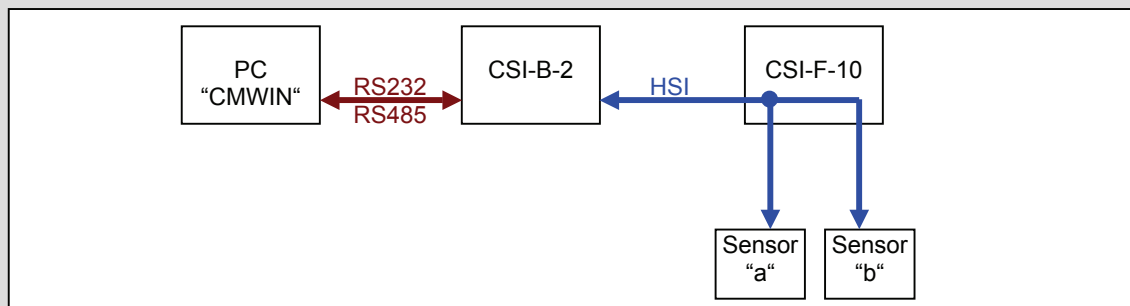

6.3.2.1 Connecting to the CSI-F-10

- Via "**Change**" in the **Bus address** line, open the selection window for the bus address and select "**Bus master**".

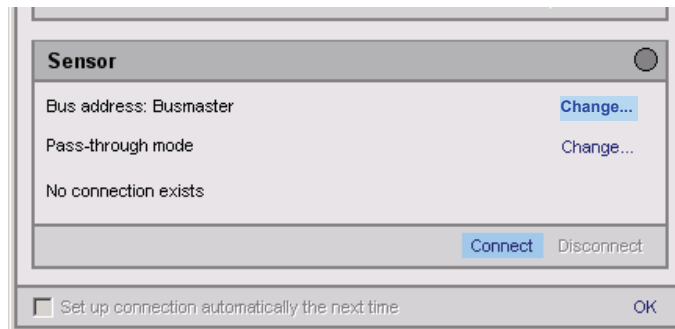

- Afterwards click on "**Connect**" in the **Sensor** field to connect the CSI-F-10 to the PC.
- The successful connection will be symbolized by a green dot on the right-hand edge of the window.

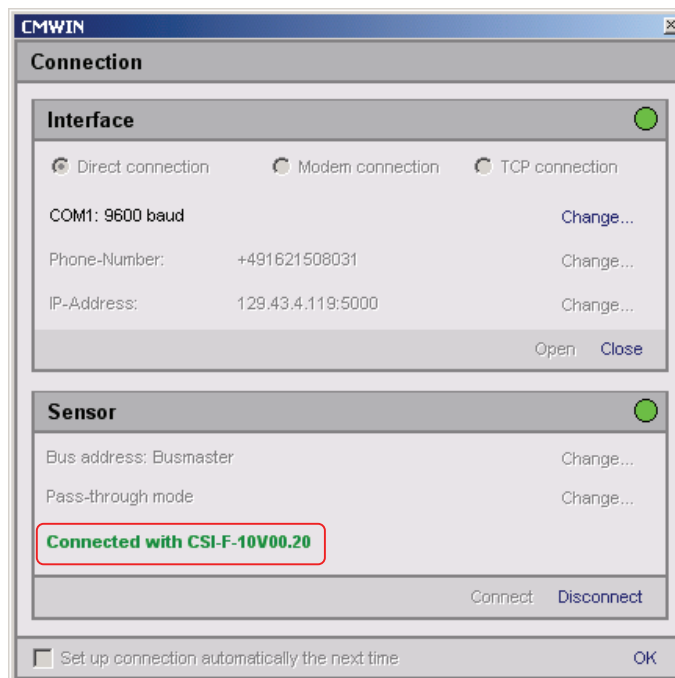

- Pressing "**Disconnect**" in the **Sensor** field allows you to break the existing connection between the CSI-F-10 and PC again.
- The interface (COM port) used can be closed again on the PC by pressing "**Close**" in the **Interface** field.
- Click on "**OK**" to complete the connection setup and to return to the CM Manager.

- The following window opens after the connection has been successfully established:

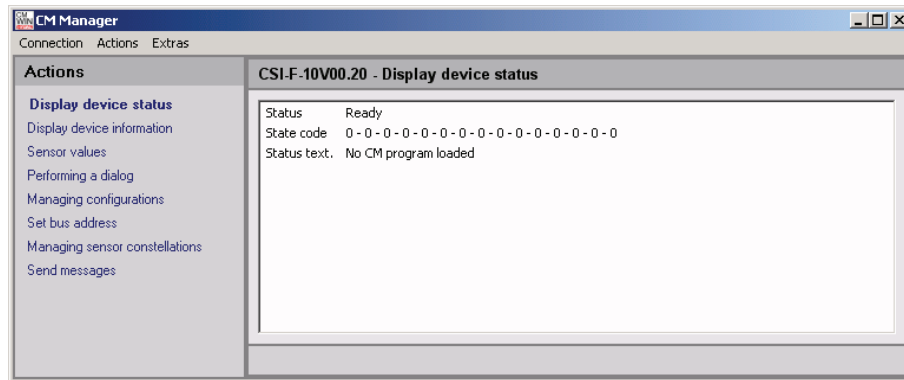

The menu structure and window properties of the CM Manager are explained below in greater detail in Chapter 7.

6.3.2.2 Connecting to the sensor by connection 1 (HSI address "a")

- Click on "Disconnect" under Connection in the Device box to break the existing PC connection with the CSI-F-10.

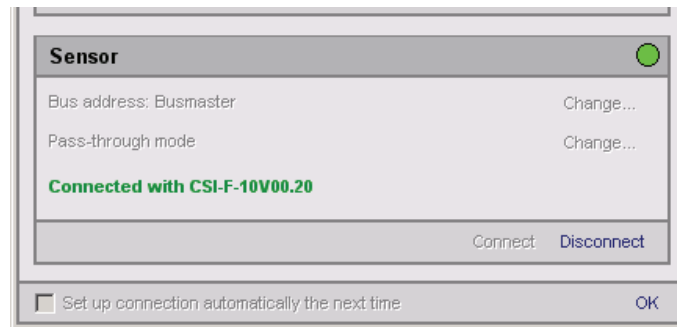

- The following window opens:

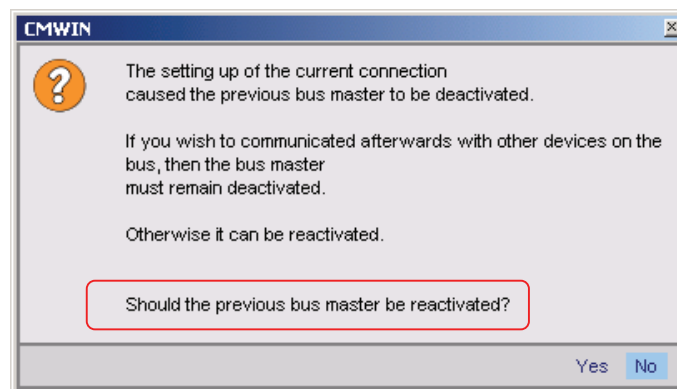

- Then click on "**No**", so that the bus master is not reactivated.
- (!)¹
- Select **Change** in the **Bus address** line.

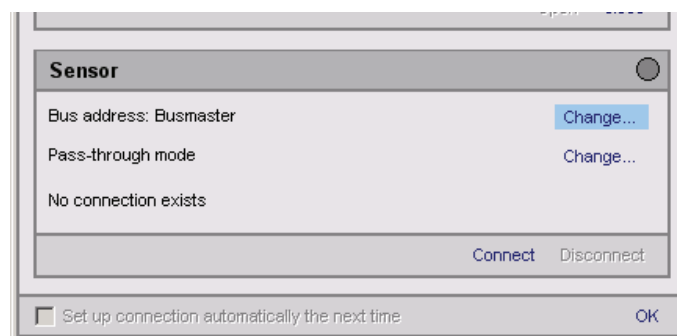

(!)¹ If you cancel at this stage and discontinue the connection to one of the connected sensors, after 5 minutes without communication a time-out occurs on the HSI bus. This time-out causes the CSI-F-10 to be switched back independently to the bus master. This is necessary so that the device can perform its monitoring function without being connected to CMWIN both in the passive and active modes.

- The following window opens:

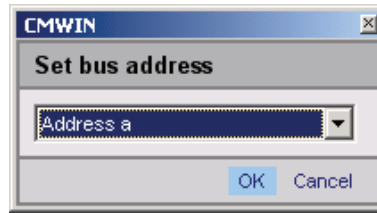

- Select the appropriate device address in the selection window (Address a in our example).
- Confirm this with **OK**.
- Click on **Connect** to establish a link with the sensor.

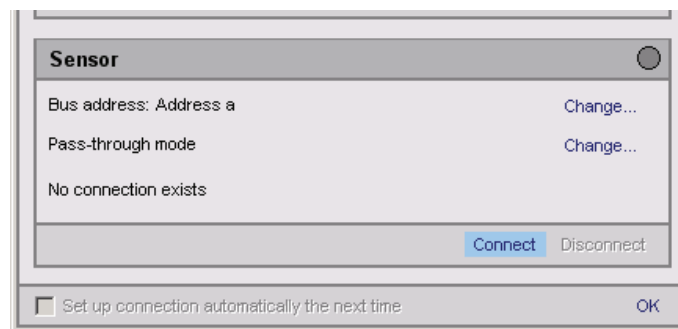

- Successful establishment of the connection will be signaled as shown below:

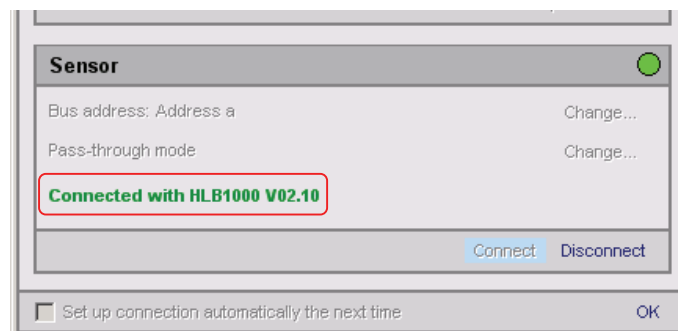

- Click on **Ok** to establish the connection setup or on **Disconnect** to cancel the connection setup.

6.3.2.3 Connecting to the sensor by connection 2 (HSI address "b")

- Click on "Disconnect" under Connection in the Device box to break the existing PC connection with the CSI-F-10.

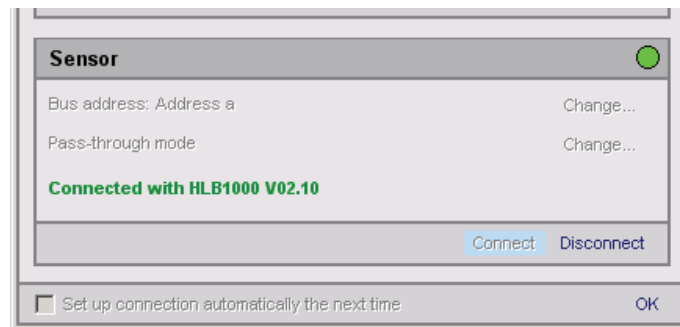

- The following window opens:

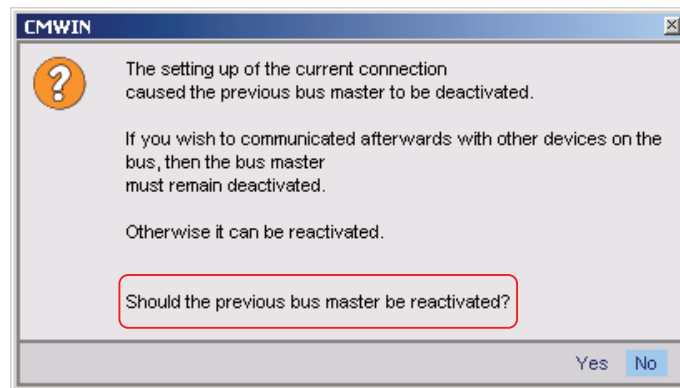

- Then click on "**No**", so that the bus master is not reactivated.
- (!)¹ see Page 30
- Select **Change** in the **Bus address** line.

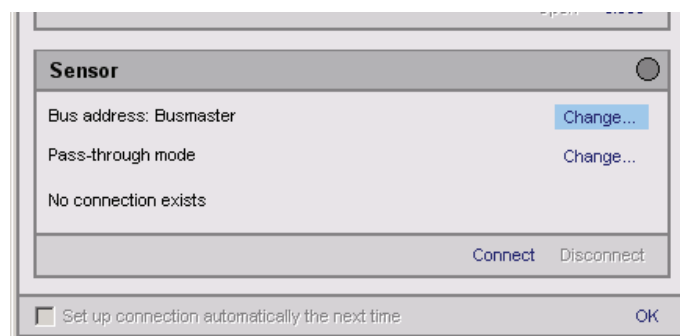

- The following window opens:

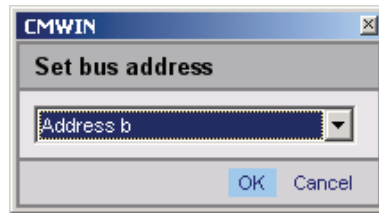

- Select the appropriate device address in the selection window (Address b in our example).
- Confirm this with **OK**.
- Click on **Connect** to establish a link with the sensor.

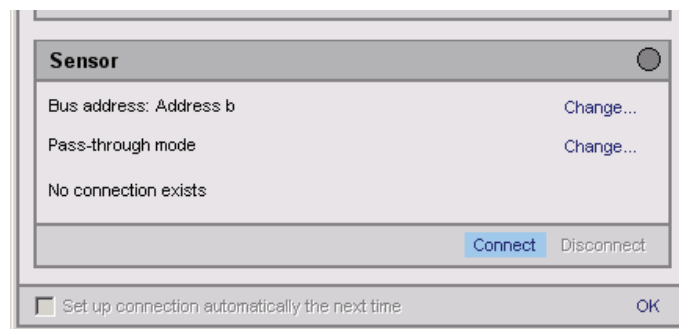

- Successful establishment of the connection will be signaled as shown below:

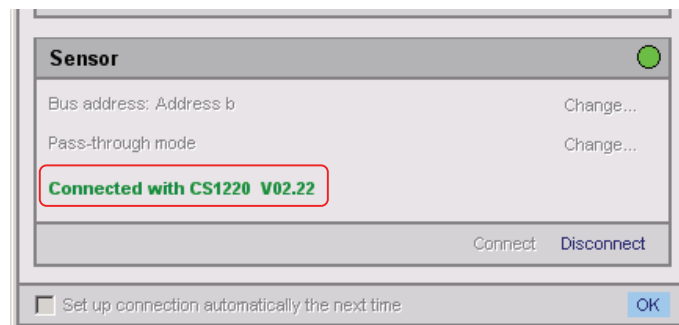

- Click on **Ok** to connect the connection setup or on **Disconnect** to cancel the connection setup.

6.4 Voltage supply with communication via direct connection to Portable Data Recorder HMG 510

If a GSM radio module is connected via a HYDAC Portable Data Recorder HMG 510 to the PC, then the GSM radio module has the HSI address "*Bus master*".

If other sensors are connected to the CSI-F-10, these must be addressed using a normal HSI address "a" or "b".

In order to communicate with the GSM radio module or with the sensors connected to it, the CSI-F-10 must first be addressed using the HSI address "*bus master*". This means the GSM modem is switched into *Slave mode* and the PC works as the bus master.

If afterwards a connected sensor is to be addressed, the connection to the GSM radio module must be disconnected. In CMWIN a query appears asking whether the master which was previously connected to the slave (the CSI-F-10) should again be the master. This query must be answered with "*No*".

After this, the connection to the sensors which are connected to the CSI-F-10 can be set up using the normal HSI addresses "a" or "b".

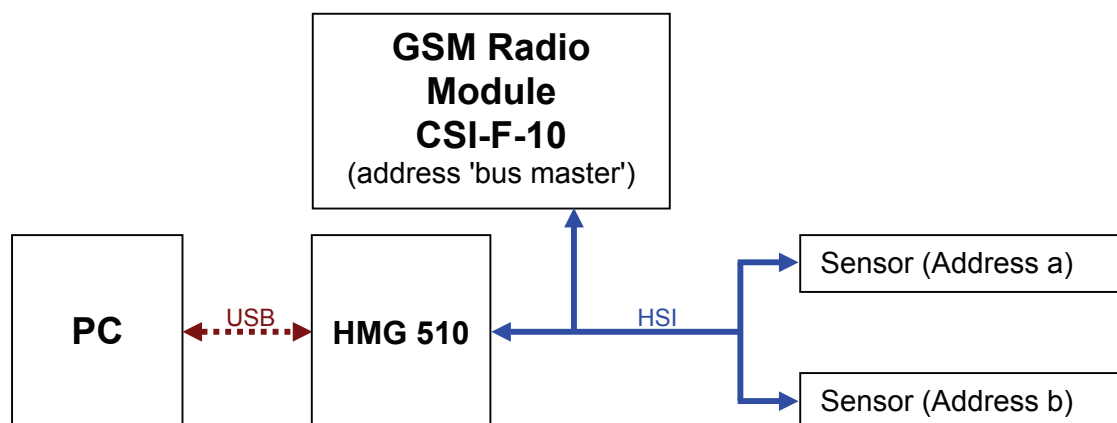

Warning!

If the GSM radio module is directly connected to the PC and CMWIN via the HYDAC interface module HMG 510 via HSI, no measured values are output and no new sensors will be recognized.

In other words, if the sensor had been connected to the GSM radio module before the connection setup, only those measured values which have been output directly prior to the connection setup appear in CMWIN.

Furthermore, new sensors must be connected to the CSI-F-10 before the connection setup because otherwise they will not be recognized.



6.4.1 Device Connection

- Connect a USB port on your PC with the USB socket of the HYDAC Portable Data Recorder HMG 510 via an appropriate data cable (USB cable is supplied with the HMG 510).
- Connect the CSI-F-10 with the HMG 510 using a 5-pole M12x1 sensor cable (e.g. ZBE 30-02 or ZBE 30-05)
- Connect the voltage supply to the CSI-F-10 GSM radio module according to the diagram.

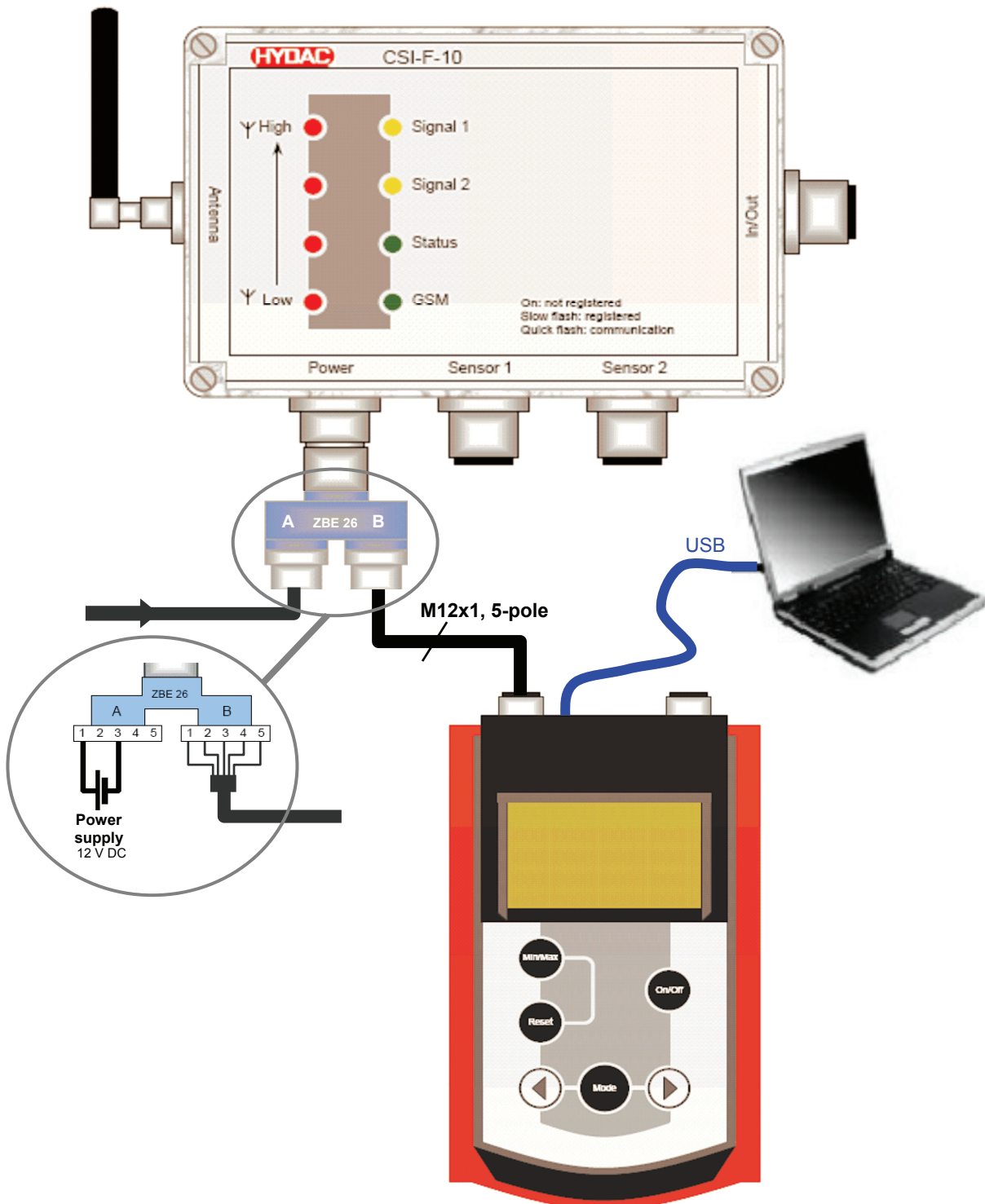

Connection Setup

- Start the HYDAC PC software **CMWIN**
- In the **Units** Menu, select the "**CM Manager**" option.



- If the **Connection** window does not open automatically, select "**Connection**" in the menu bar of the CM Manager.
- Select the option "**Direct connection**" in the window that opens.
- Click on "**Change**" in the top line to open the window for the interface settings.

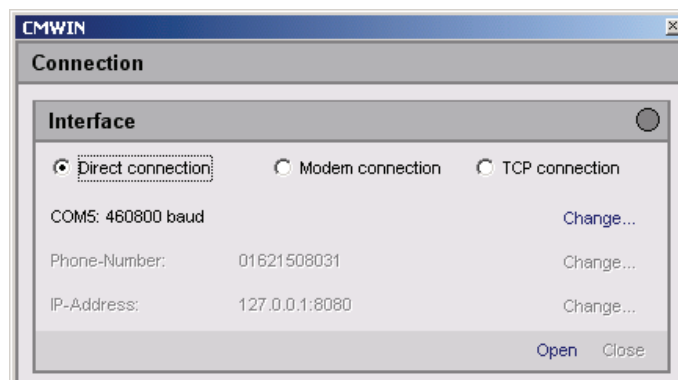

- Make the corresponding preselection for the port settings in the window that opens under **Interface selection**.
- Select the relevant port address and Baud rate (9600 für HMG 510) under **Interface settings**.
- Click "**Refresh**" to update the interfaces marked under **Interface selection** in terms of availability.
- Click on "**OK**" to apply the modified settings or "**Cancel**" to discard these changes. In either case you will then return to the **Connection** window.

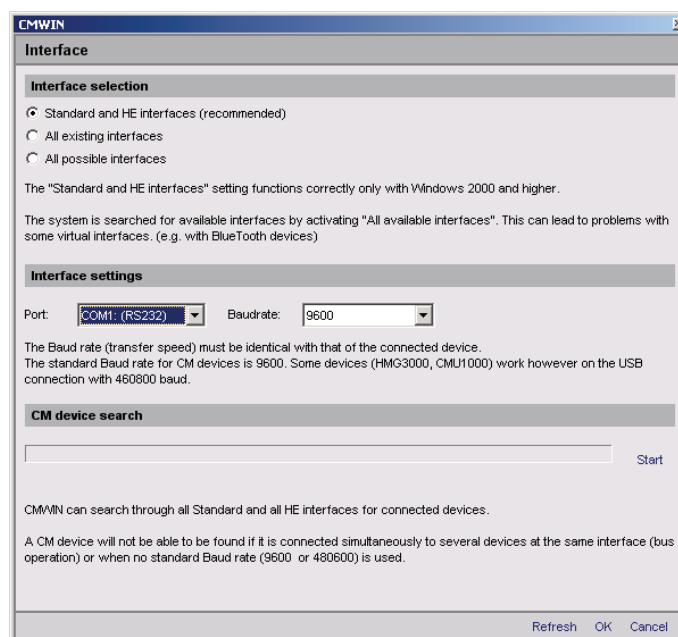

- In the **Interface** field, select the option "**Open**" in order to open the selected interface (COM port).
The opened interface will be indicated by a green dot on the right-hand edge of the window.

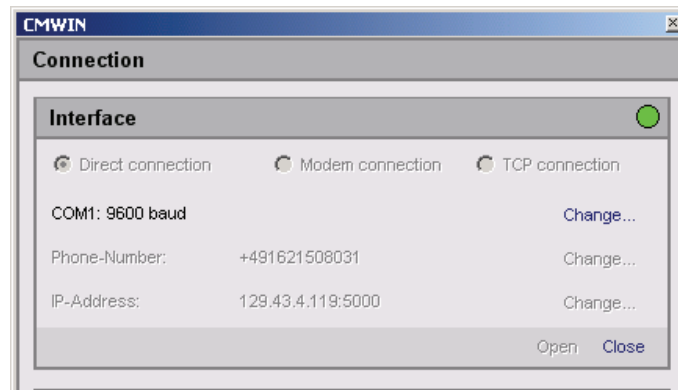

- In the **Sensor** field, specify whether you would like to connect to the CSI-F-10 GSM radio module direct, or to one of the sensors connected to it.

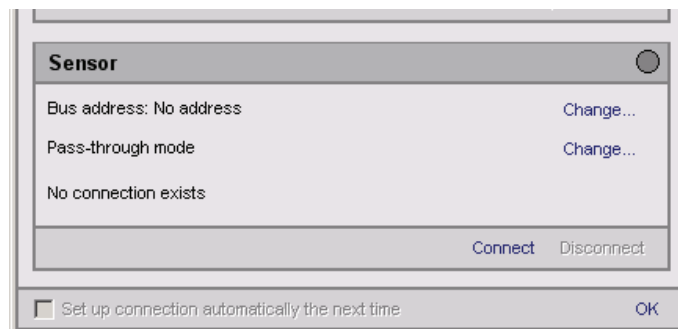

- Click on "**Change**" to open the window for the pass-through mode.
- Select **Switch on**, to transfer the HMG 510 into the pass-through mode. Afterwards the following message appears:

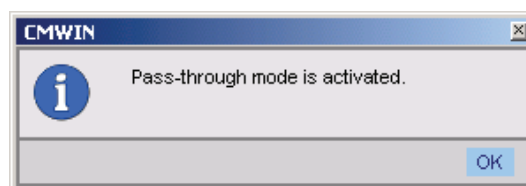

- Confirm this with **OK**.
- "**Com Mode**" appears in the display of the HMG 510.

Note!

In the pass-through mode a device connected to the PC (in this case: HMG 510) transfers the data direct to on of the connected sensors or to another device (in this cae: CSI-F-10) and vice-versa. The PC is then no longer linked to the device directly connected to it.

In the following example, a HYDACLab® with the address "a" is connected to connection 1 and a CS 1000 is connected to a CS 1000 with the address "b" (see also Chapter 6.3.2).

- Afterwards, proceed according to the three options described below.

6.4.2.1 Connecting to the CSI-F-10

- Via "**Change**" in the **Bus address** line, open the selection window for the bus address and select "**Bus master**".

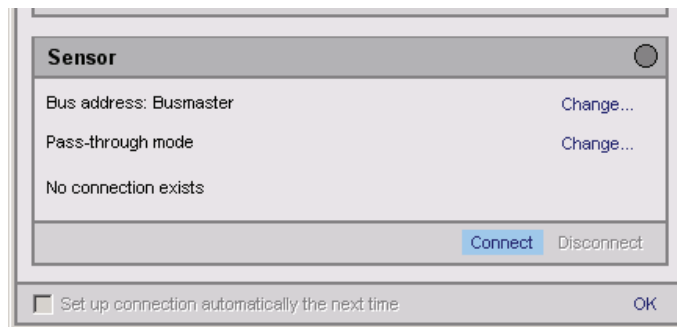

- Afterwards click on "**Connect**" in the **Sensor** field to connect the CSI-F-10 to the PC.
- The successful connection will be symbolized by a green dot on the right-hand edge of the window.

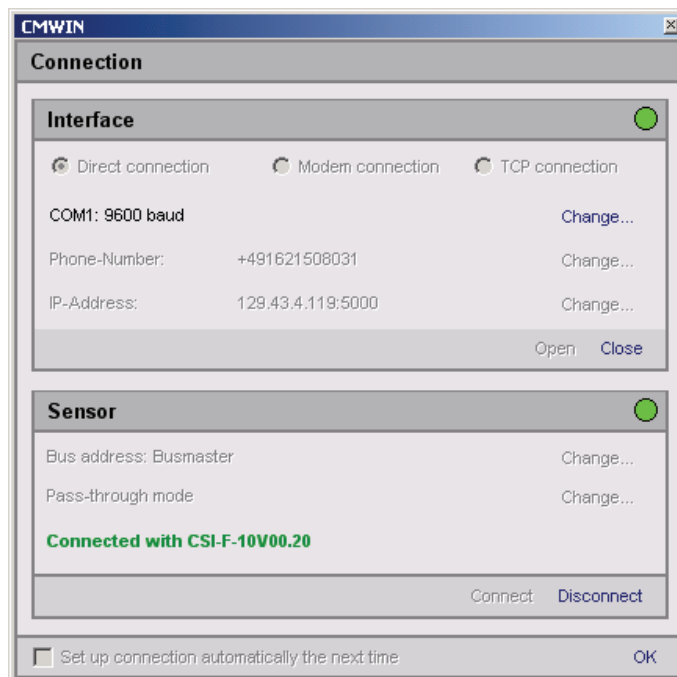

- Pressing "**Disconnect**" in the **Sensor** field allows you to break the existing connection between the CSI-F-10 and PC again.
- The interface (COM port) used can be closed again on the PC by pressing "**Close**" in the **Interface** field.
- Click on "**OK**" to complete the connection setup and to return to the CM Manager.

- The following window opens after the connection has been successfully established:

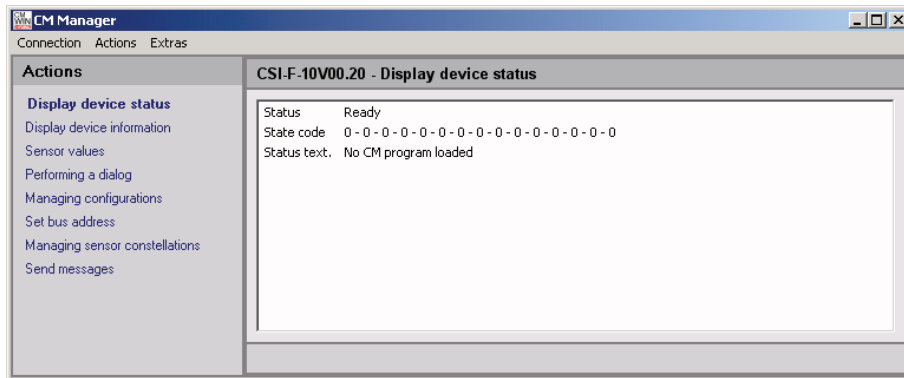

The menu structure and window properties of the CM Manager are explained below in greater detail in Chapter 7.

6.4.2.2 Connecting to the sensor by connection 1 (HSI address "a")

- Click on "Disconnect" in the Device box to break the existing PC connection with the CSI-F-10.

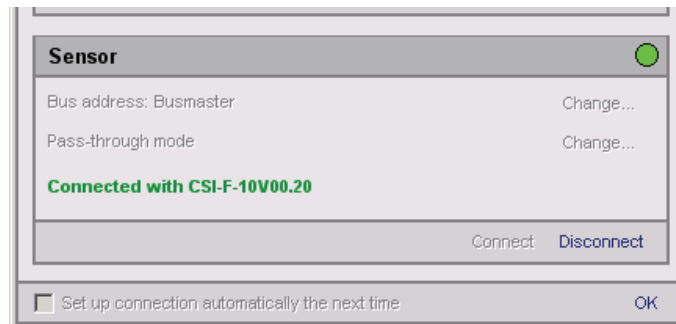

- The following window opens:

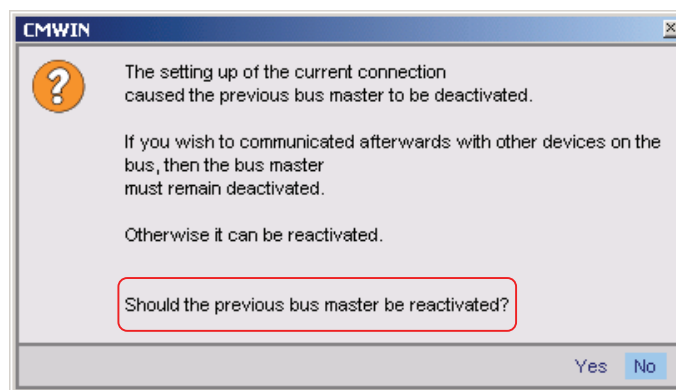

- Then click on "**No**", so that the bus master is not reactivated.
- (!)¹
- Select **Change** in the **Bus address** line.

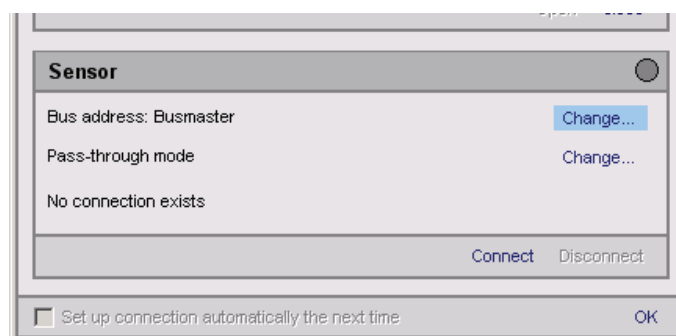

(!)¹ If you cancel at this stage and discontinue the connection to one of the connected sensors, after 5 minutes without communication a time-out occurs on the HSI bus. This time-out causes the CSI-F-10 to be switched back independently to the bus master. This is necessary so that the device can perform its monitoring function without being connected to CMWIN both in the passive and active modes.

- The following window opens:

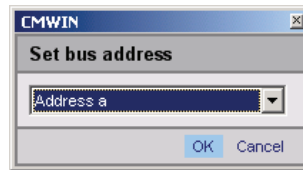

- Select the appropriate device address in the selection window (Address a in our example).
- Confirm this with **OK**.
- Click on **Connect** to establish a link with the sensor.

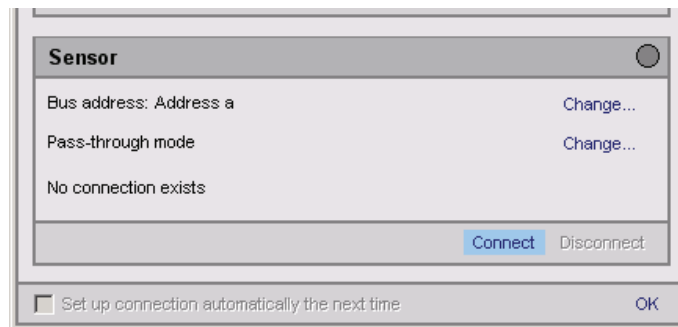

- Successful establishment of the connection will be signaled as shown below:

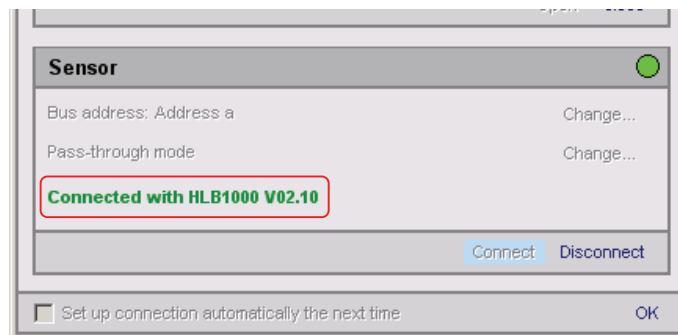

- Click on **Ok** to establish the connection setup or on **Disconnect** to cancel the connection setup.

6.4.2.3 Connecting to the sensor by connection 2 (HSI address "b")

- Click on "Disconnect" in the Device box to break the existing PC connection with the CSI-F-10.

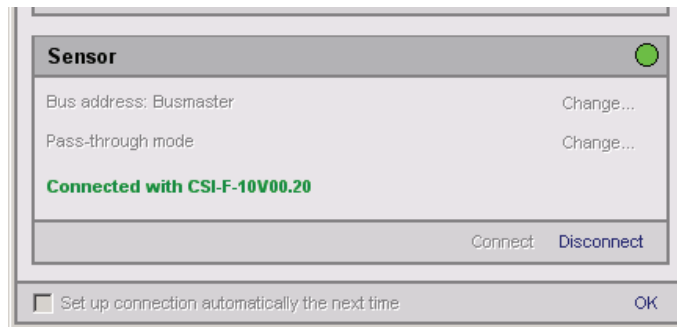

- The following window opens:

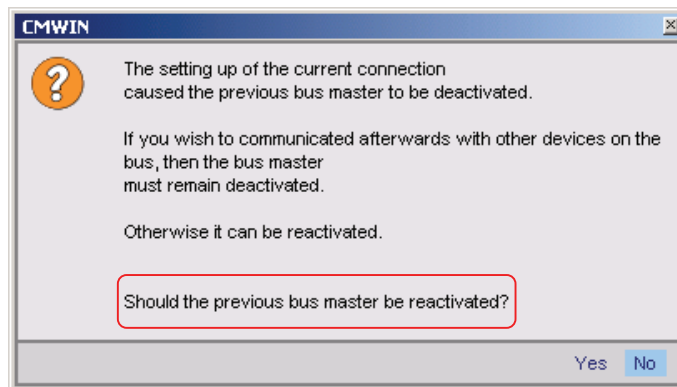

- Then click on "**No**", so that the bus master is not reactivated.
- (!)**¹ see Page 40
- Select **Change** in the **Bus address** line.

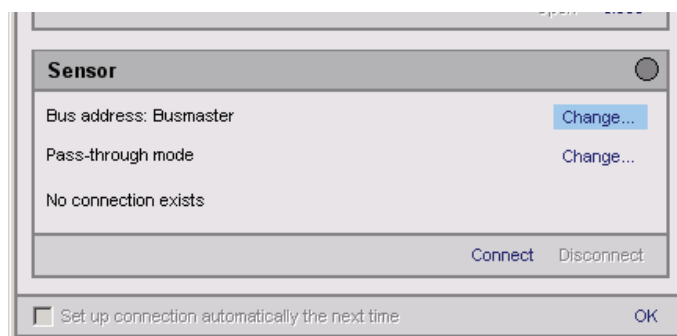

- The following window opens:

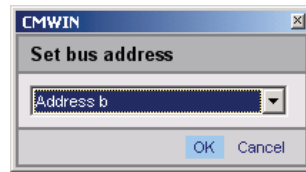

- Select the appropriate device address in the selection window (Address b in our example).
- Confirm this with **OK**.
- Click on **Connect** to establish a link with the sensor.

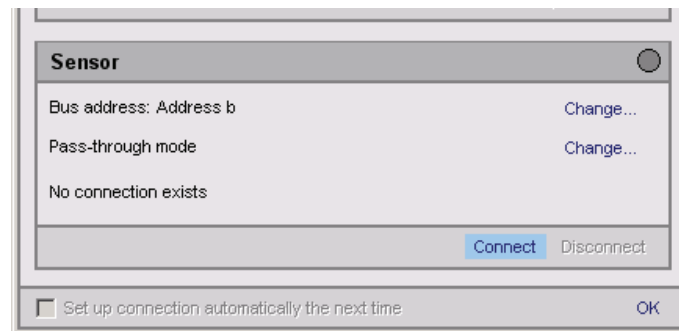

- Successful establishment of the connection will be signaled as shown below:

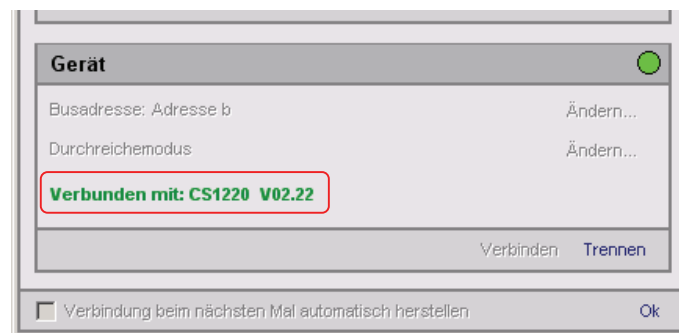

- Click on **Ok** to establish the connection setup or on **Disconnect** to cancel the connection setup.

6.5 Voltage supply with communication via GSM mobile radio connection (standard application)

Note!



In order to be able to communicate with the CSI-F-10 using GSM mobile radio, this must first be configured. This means that the mobile phone numbers which are authorized for access must be stored in the CSI-F-10 and appropriate permissions assigned.

In order to configure the GSM radio module CSI-F-10, first connect with the GSM radio module CSI-F-10 as previously described (e.g. via CSI-B-2, HMG 510 or CMU 1000).

If the CSI-F-10 GSM radio module is operated with the aid of a PC modem via a GSM mobile radio connection, communication occurs using a special protocol.

In this case the CSI-F-10 does not have an HSI address, because it is activated via the special protocol for modem connections and only a point to point connection is possible in this protocol.

If sensors are connected to the CSI-F-10, the GSM radio module can be transferred to the pass-through mode. In the pass-through mode, the sensors can be accessed using the normal HSI addresses "a" ... "z".

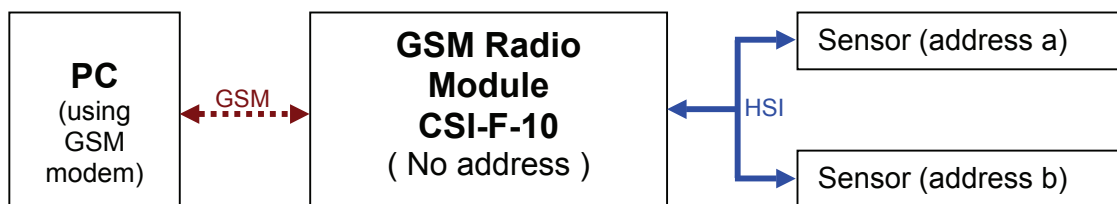

For the GSM-Modem for the PC connection, we recommend the following device:

- "GPRS GSM Quadband Modem / USB"; Manufacturer: ConiuGo GmbH (www.coniugo.com)



Warning!

If the time of day or date of the GSM radio module is modified via a mobile radio connection, then the new time is only visible at the next connection setup in CMWIN. Time of day and date are however changed immediately in the CSI-F-10.

6.5.1 Device connection

- Connect your PC with a standard GSM modem and make sure the device is ready for operation.
- Insert a valid SIM card into the CSI-F-10 GSM radio module (see Chap. 6.1).
- Connect the voltage supply to the CSI-F-10 GSM radio module according to the diagram.

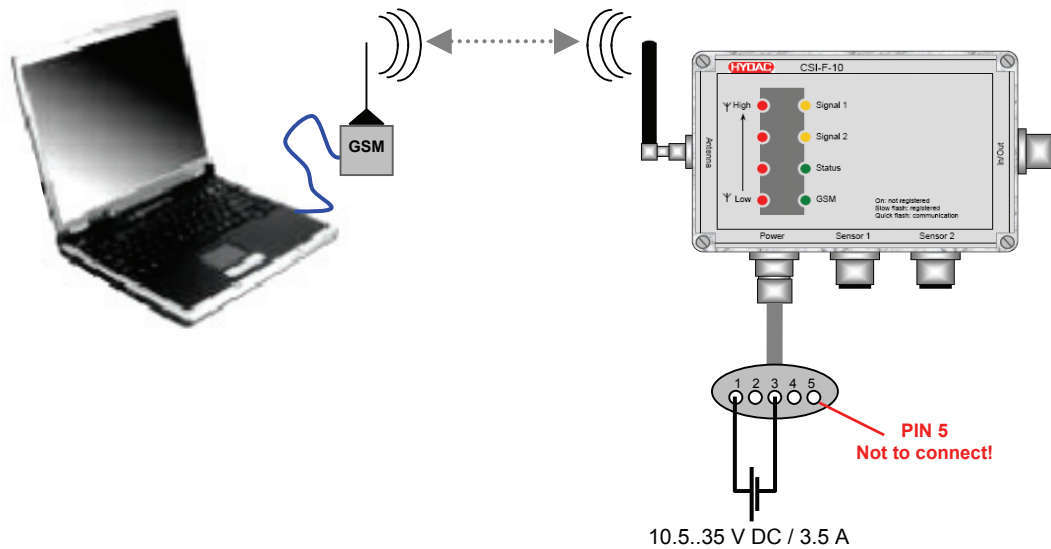

6.5.2 Connection Setup

- Start the HYDAC PC software **CMWIN**
- In the **Units** Menu, select the **"CM Manager"** option.

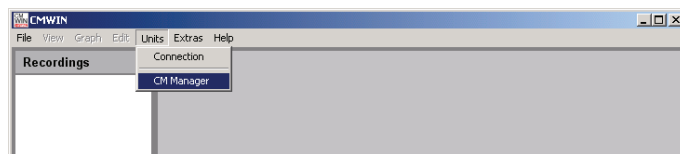

- If the **Connection** window does not open automatically, select **"Connection"** in the menu bar of the CM Manager.
- Select the option **"Modem Connection"** option in the window that opens.
- Click on **"Change"** in the top line to open the window for the interface settings.

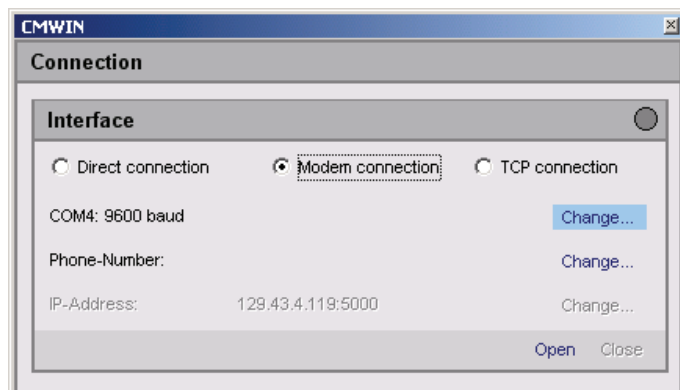

- Make the corresponding preselection for the port settings in the window that opens under **Interface selection**.
- Select the relevant port address and Baud rate (9600 for GSM) under **Interface settings**.
- Click "**Refresh**" to update the interfaces marked under **Interface selection** in terms of availability.
- Click on "**OK**" to apply the modified settings or "**Cancel**" to discard these changes. In either case you will then return to the **Connection** window.

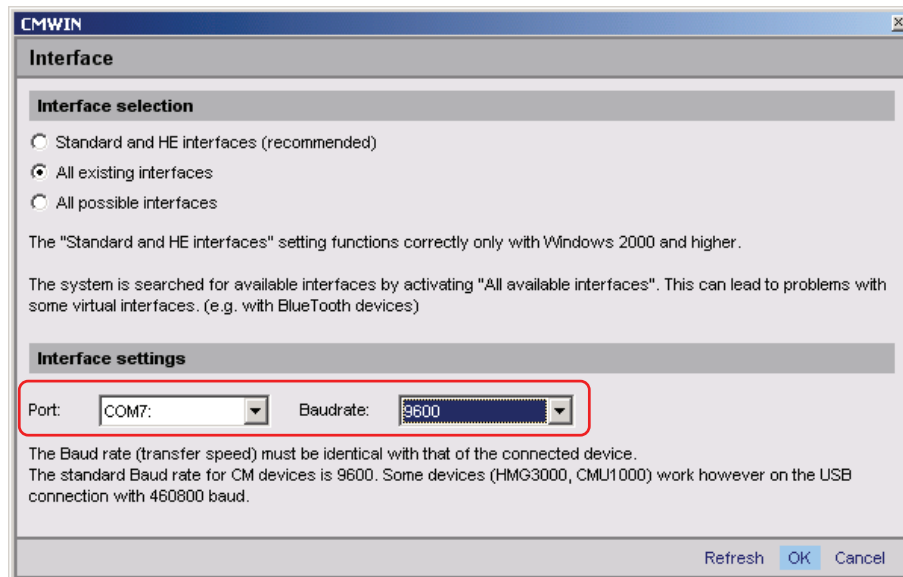

- Click on "**Modify**" in the **Telephone number** line to open the window for inputting telephone numbers.
- Enter the telephone number of the SIM card mounted in the GSM module CSI-F-10.
- In the **Pin** field enter the PIN code (if one has been assigned) for the SIM card of the modem connected to the PC. If no PIN code has been assigned, then leave the field empty.
- You can set up a list of telephone numbers (address book) under **Telephone list**.
- Click on "**OK**" to apply the entries or "**Cancel**" to discard these changes. In either case you will then return to the **Connection** window.

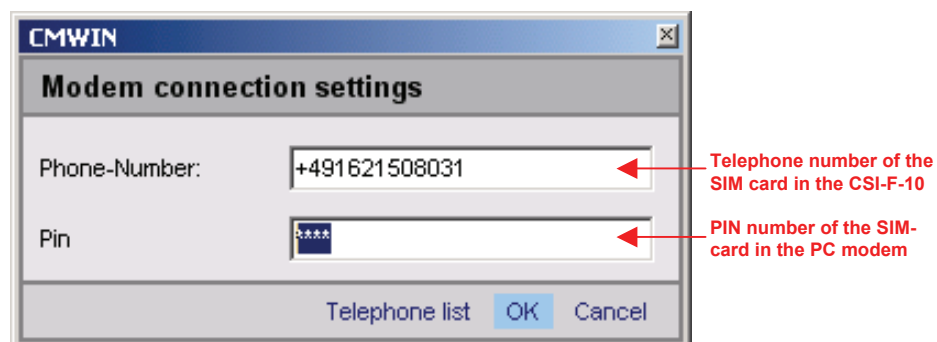

- Click on **"Open"** to open the selected interface. The opened interface is then indicated by a green dot at the top right.
(Warning: The selection process can take up to a minute!)

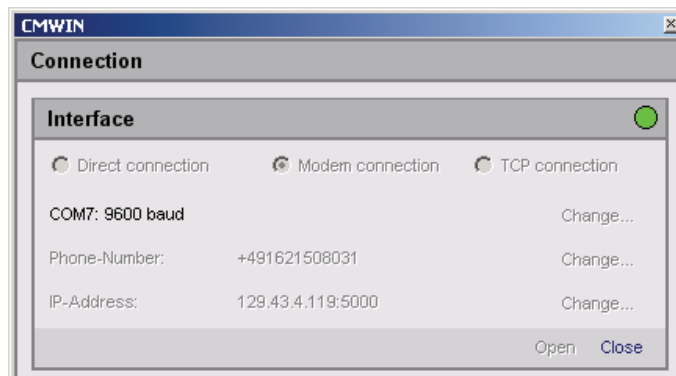
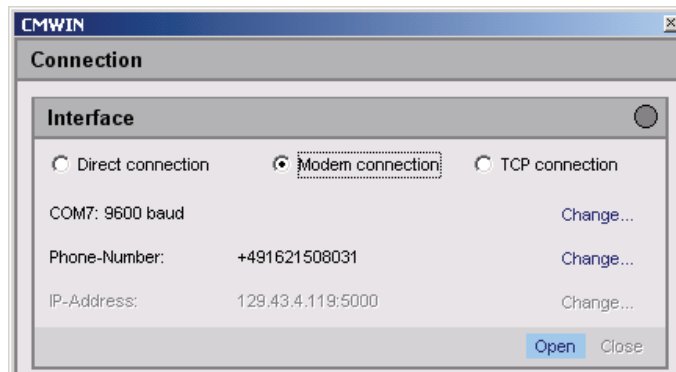

- Click on **"Change"** to open the window for the pass-through mode and then proceed according to the options described below.

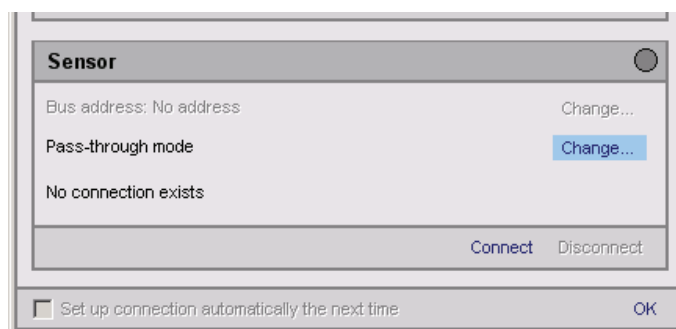

6.5.2.1 Connecting to the CSI-F-10

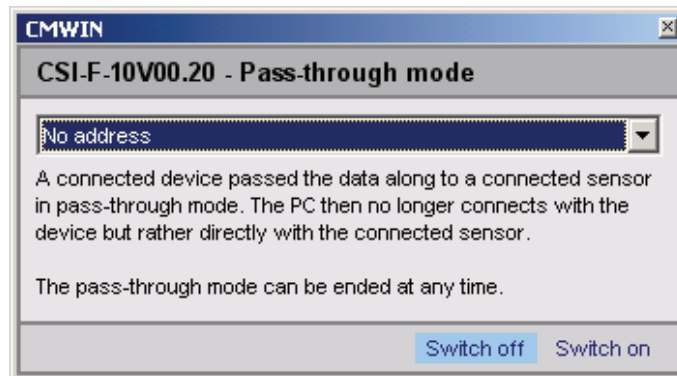

- Select **No address** and then **Switch off**. The following message appears

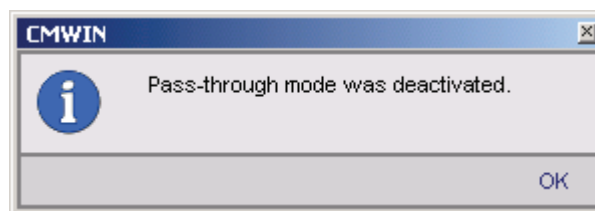

- Confirm this with **OK**.

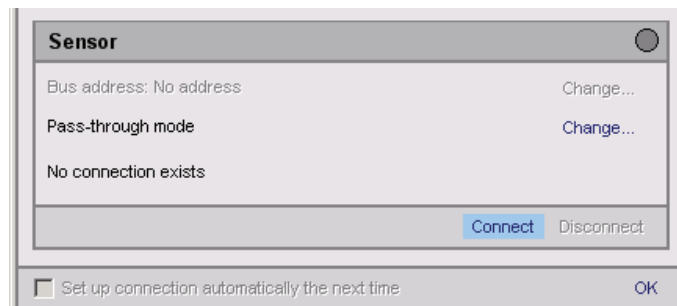

- Click on **Connect** to establish a link with the CSI-F-10.

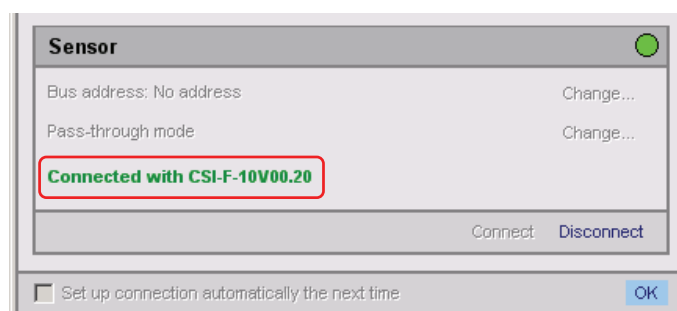

- Click on **Ok** to establish the connection setup or on **Disconnect** to cancel the connection setup.

- The following window opens after the connection has been successfully established:

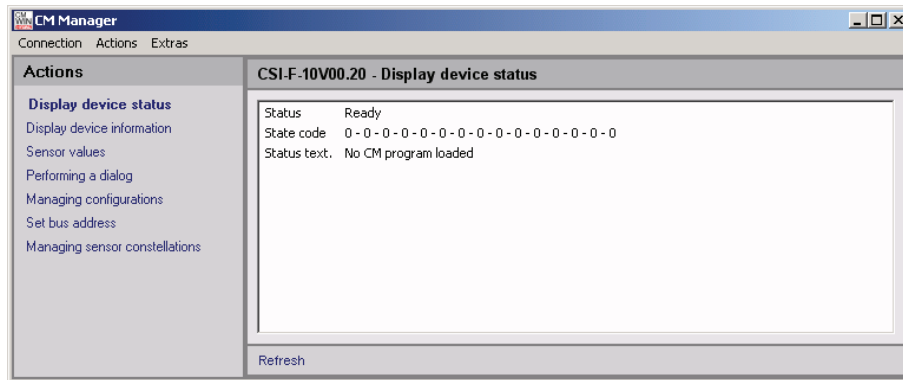

The menu structure and window properties of the CM Manager are explained below in greater detail in Chapter 7 ff.

6.5.2.2 Connecting to the sensor by connection 1 (HSI address "a")

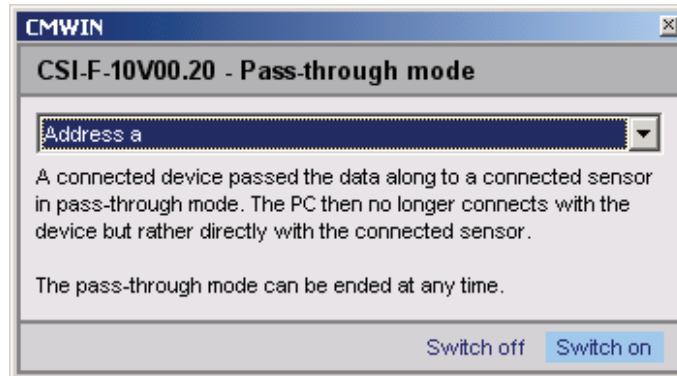

- Select **Address a** and then **Switch on**. The following message appears

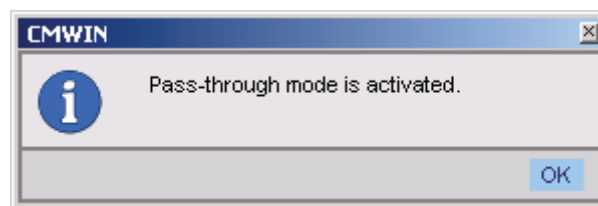

- Confirm this with **OK**.

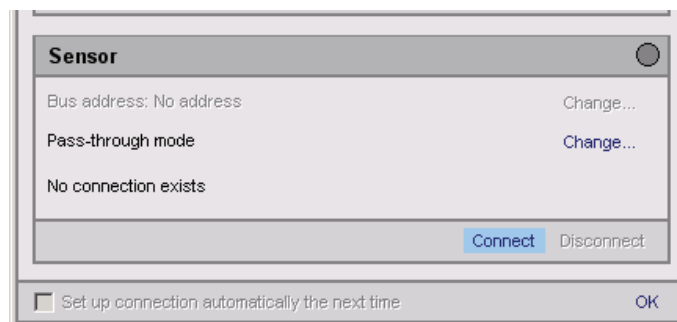

- Click on **Connect** to establish a link with the sensor.

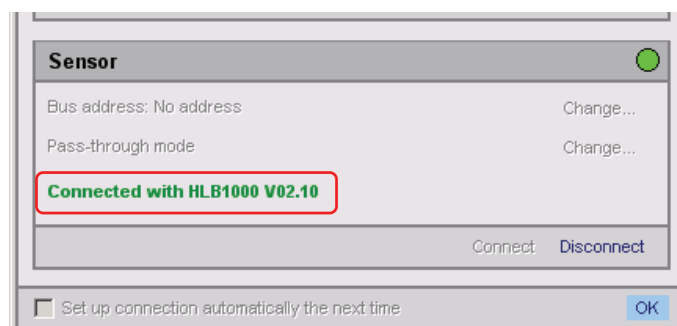

- Click on **Ok** to continue with the connection setup or on **Disconnect** to cancel the connection setup.

6.5.2.3 Connecting to the sensor by connection 2 (HSI address "b")

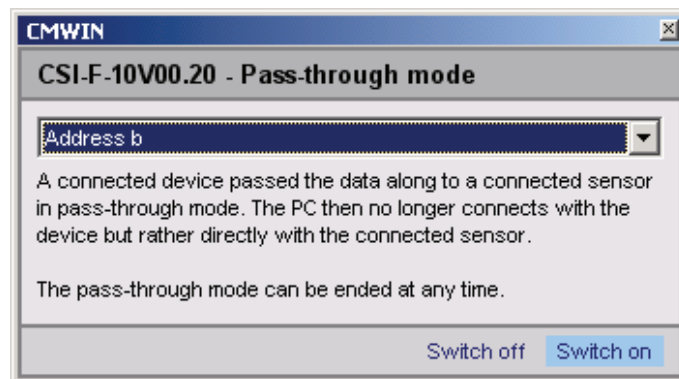

- Select **Address b** and then **Switch on**. Afterwards the following message appears:

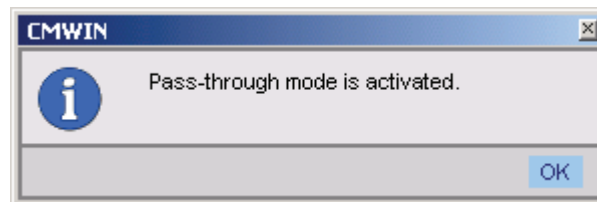

- Confirm this with **OK**.

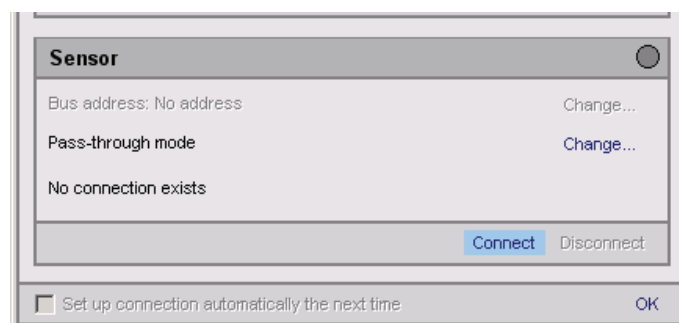

- Click on **Connect** to establish a link with the sensor.

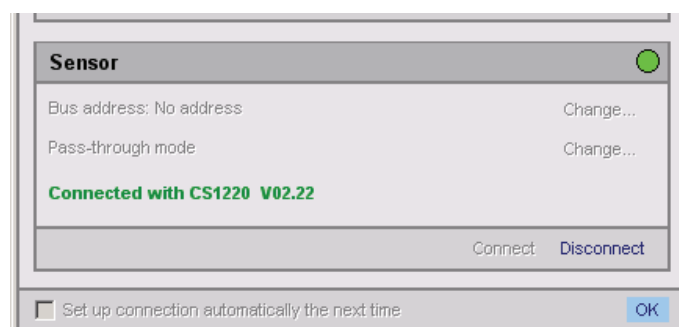

- Click on **Ok** continue with the connection setup or on **Disconnect** to cancel the connection setup.

6.6 Voltage supply and communication via Condition Monitoring Unit CMU 1000

If the CSI-F-10 GSM radio module is being operated on a Condition Monitoring Unit CMU 1000 (see Chap. 3.2), the communication between the two units occurs via the HSI Master Connection (power connection).

In this case, the CSI-F-10 must be switched into the pass through mode to be able to access the CMU 1000 from the PC.

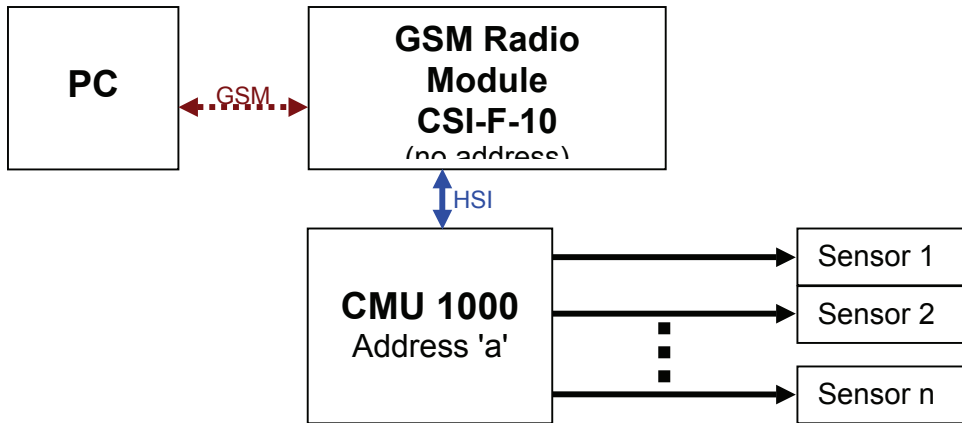

Note!

If the CSI-F-10 is connected to a CMU 1000, then, apart from registering the authorized telephone numbers (see Chap. 7.1.4.1), no settings must be made on the GSM radio module. All activities come from the CMU 1000 in this case. Also, an HSI address (in our example "a") must be assigned to the connected CMU 1000 and the interface must be set to "HSI".



6.6.1 Device Connection

- Connect a standard GSM modem to your PC and connect the CMU 1000 to the GSM radio module CSI-F-10 as per the diagram below.

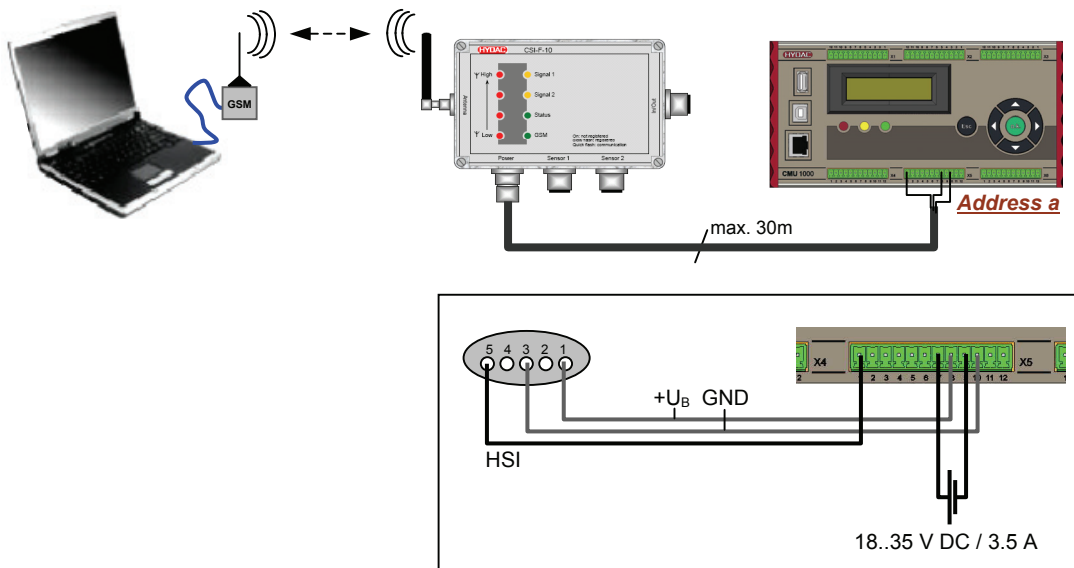

6.6.2 Connection Setup

- Start the HYDAC PC software **CMWIN**
- In the **Units** Menu, select the "**CM Manager**" option.



- If the **Connection** window does not open automatically, select "**Connection**" in the menu bar of the CM Manager.
- Select the option "**Modem Connection**" option in the window that opens.
- Click on "**Change**" to open the window for the interface settings.

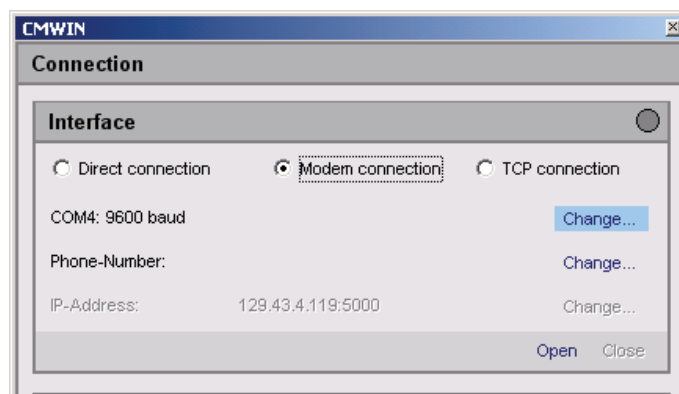

- Make the corresponding preselection for the port settings in the window that opens under **Interface selection**.
- Select the relevant port address and Baud rate (9600 for GSM) under **Interface settings**.
- Click "**Refresh**" to update the interfaces marked under **Interface selection** in terms of availability.
- Click on "**OK**" to apply the modified settings or "**Cancel**" to discard these changes. In either case you will then return to the **Connection** window.
- Click on "**Change**" to open the window for entering the telephone numbers.

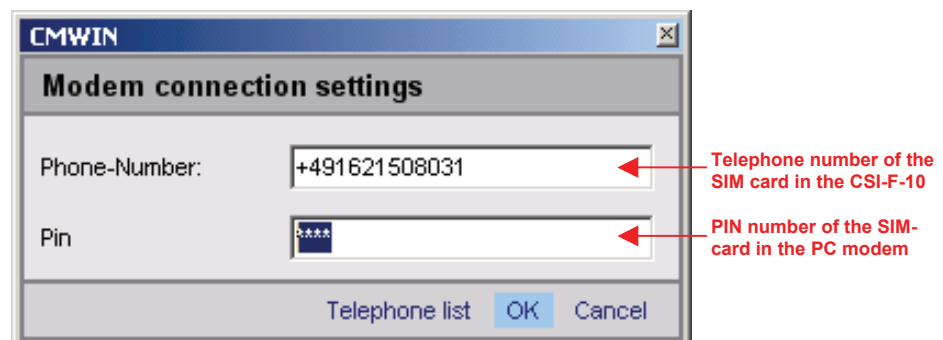

- Enter the telephone number of the SIM card which is in the GSM radio module CSI-F-10.
- In the **Pin** field enter the PIN code (if one has been assigned) for the SIM card of the modem connected to the PC. If no PIN code has been assigned, then leave the field empty.

- You can set up a list of telephone numbers (address book) under **Telephone list**.
- Click on **OK** to apply the entries or **Cancel** to discard these changes. In either case you will then return to the **Connection** window.

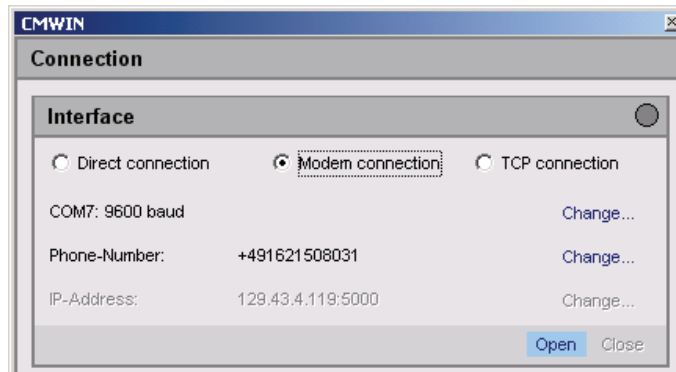

- Click on **Open** to open the selected interface. The open interface is indicated by a green dot at the top right.
- Click on **Change** to open the window for the pass-through mode.

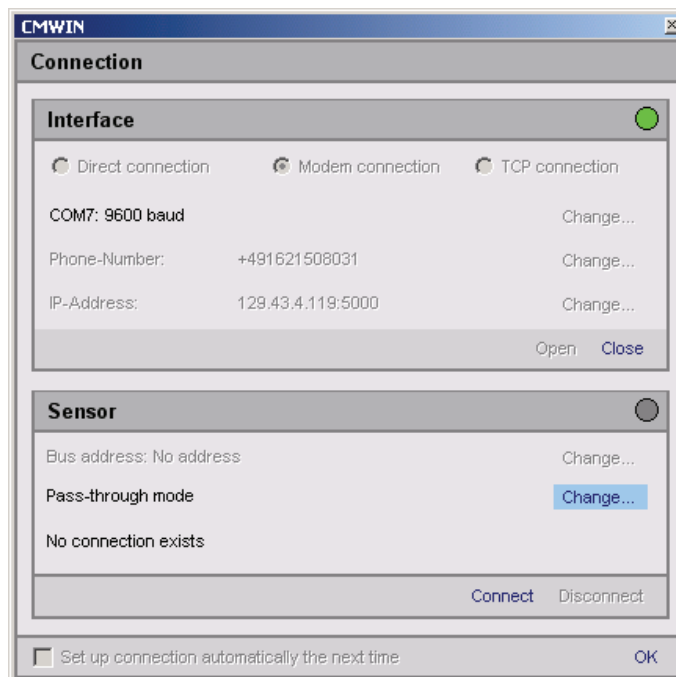

- Select the HSI address of the CMU 1000 connected to the CSI-F-10 in the selection window (Address a in our example).
- Afterwards, click on **Switch on** in order to switch on the pass-through mode for the selected channel.

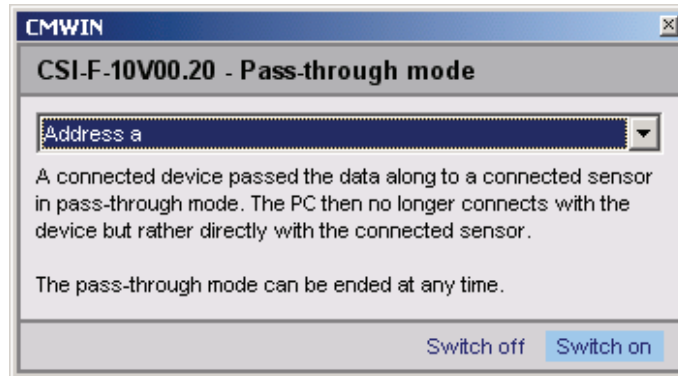

- The following message appears:

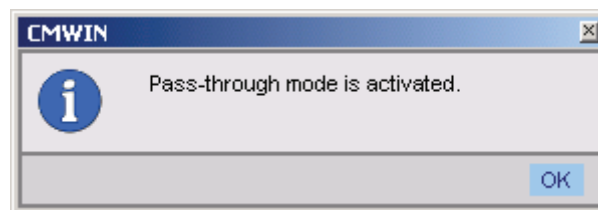

- Confirm this with **OK**.

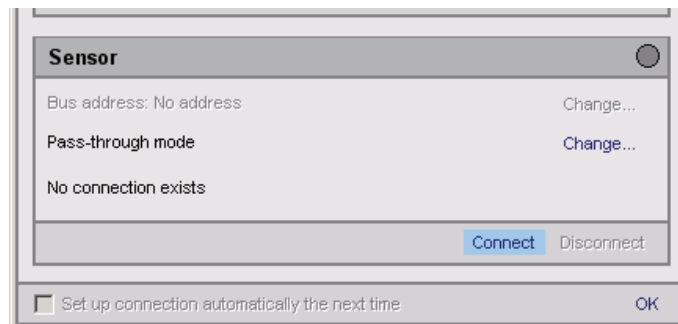

- Afterwards click on **Connect** to connect the PC to the CMU 1000 that is connected with the CSI-F-10

- Successful establishment of the connection will be signaled as shown below:

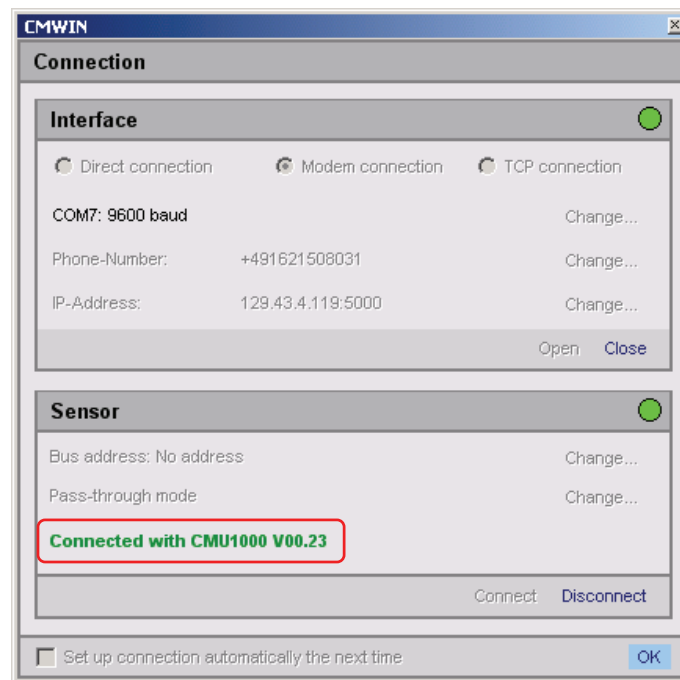

- End the connection setup by confirming with **OK**.

7 Configuration Using CMWIN PC Software

Configuration of the CSI-F-10 and implementation of the basic settings can also be carried out using the "CM Manager" from a PC.

The "CM Manager" is a component part of the **CMWIN** HYDAC PC software, starting with Version 3, and provides you with various tools and functions for the connecting, configuring, parameterizing and outputting of CM devices.

7.1 Actions

7.1.1 Display Device Status

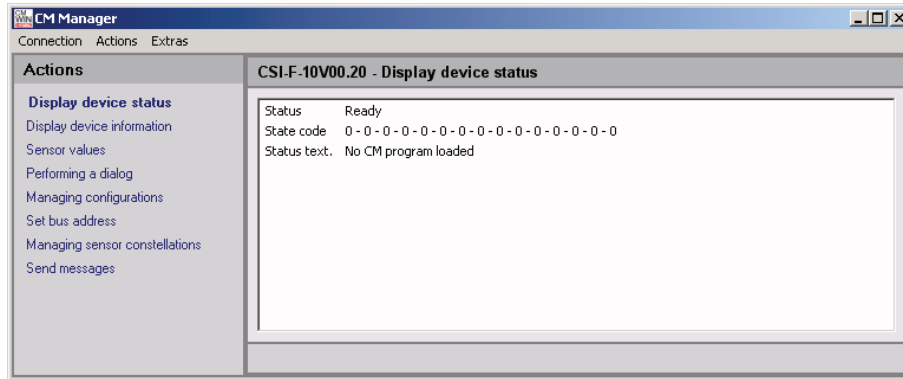

- Status**
 The "Status" indicates the current condition of the device. The individual conditions can be specified in greater detail via the following table.

Ready	No active error present, device is ready for operation
Stand-By	No active error present, but device is currently not ready for operation; it may be that individual device functions are switched off or the device is in a startup phase, etc.
Minor error	A minor error is present which can be acknowledged.
Moderate error	A medium-serious error is present, which may possibly be eliminated by switching On/Off.
Serious error	A serious error is present; the unit must be sent in to the manufacturer.

- Status code**
 The "Status code" is dependent on the CM Program present in the device and reflects the conditions of the Boolean output values used in the program. For this, the Boolean output values are displayed from right to left in ascending binary sequence, i.e. the lowest-value bit corresponds to the Boolean output value 0.

Example:

0 = No Boolean output values used in the program
 1 0 1 0 = Boolean output value 0 = 0 (LSB)
 Boolean output value 1 = 1
 Boolean output value 2 = 0
 Boolean output value 3 = 1 (MSB)

- Status text**
 The "Status text" indicates whether or not a CM Program is available in the device.

No script loaded	No CM Program is available in the device.
Script is loaded	A CM Program is available in the device.

7.1.2 Display Device Information

- Here the values of the following status parameters are displayed:
 - Part number
 - Serial number
 - Channel information

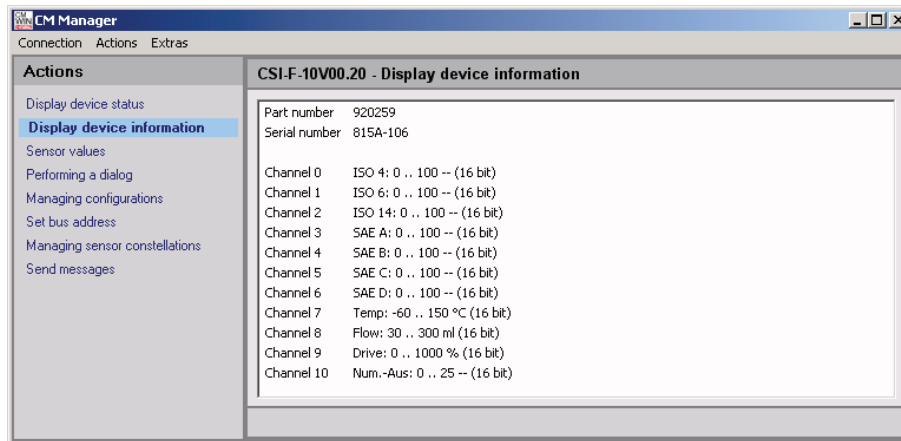

The channel information reflects the numerical output values from the CM program. Channel 0 corresponds to the first numerical output value in the CM Program, Channel 1 the second, etc.

The upper and lower limits and the units stored in the CM program are displayed.

If no CM Program is available in the device, then the connected sensors will be displayed at this point with sub-channels, measurement ranges and units.

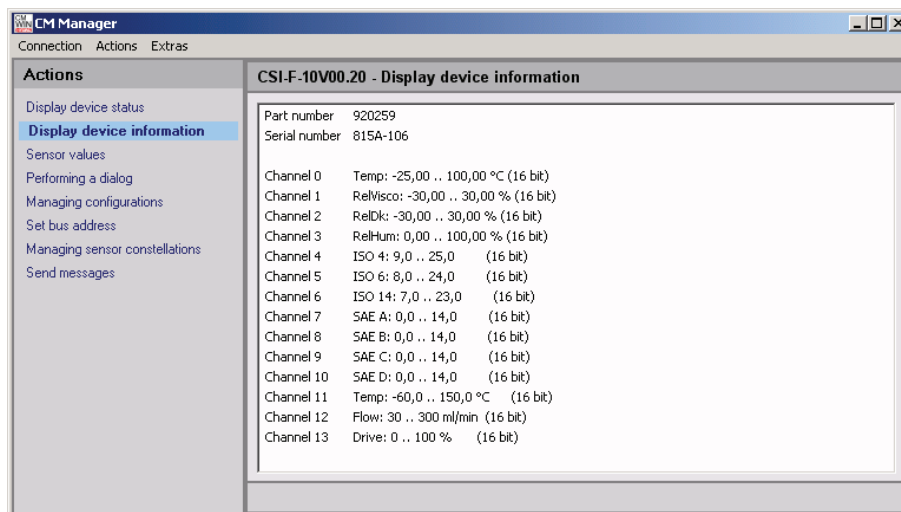

The upper and lower limits and the units stored in the sensor are displayed.

7.1.3 Display Measured Values

- Here the results of the numerical output values from the CM program in the device are displayed.

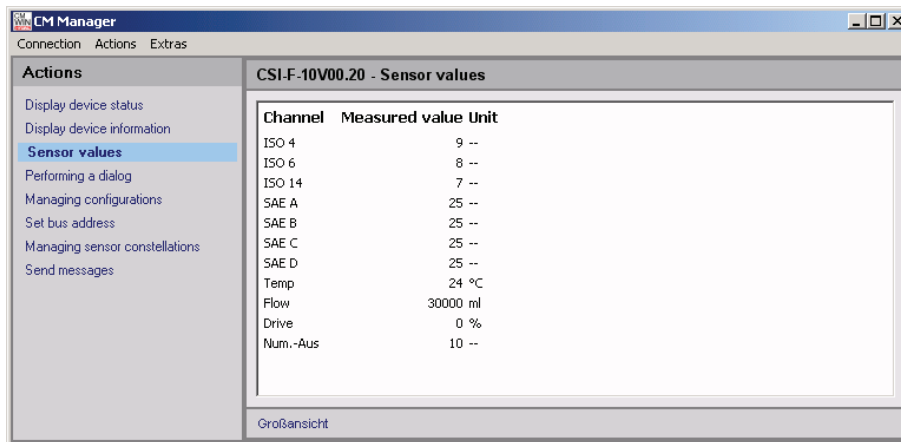

If no CM Program is available in the device, then the measured values of the connected sensors will be displayed.

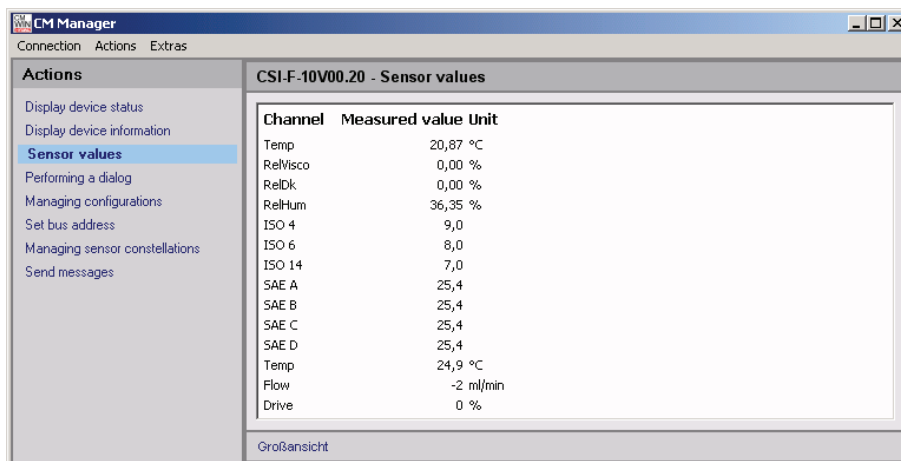

7.1.4 Setup

Under this menu point, the following settings can be made and output:

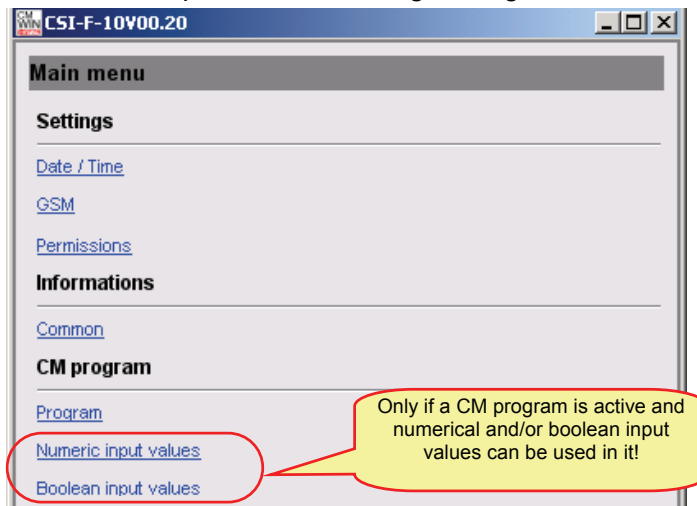

7.1.4.1 Program settings

- **Date / Time**
Date [input actual date]
Time [input actual time of day]



Click on "**Apply**", to apply the settings. "**Back**" takes you back to the main menu.

- **GSM**
IMEI [displays the IMEI no. of the device]
Own phone number [displays the own phone number]
Signal strength / % [displays the actual network intensity]
Service provider [displays the network operator of the SIM card]
Frequency band [Select frequency range:
900/1800 MHz or 850/1900 MHz]
GSM-Watchdog [activate / deactivate GSM-Watchdog *]
PIN [input the PIN code of the SIM card **]

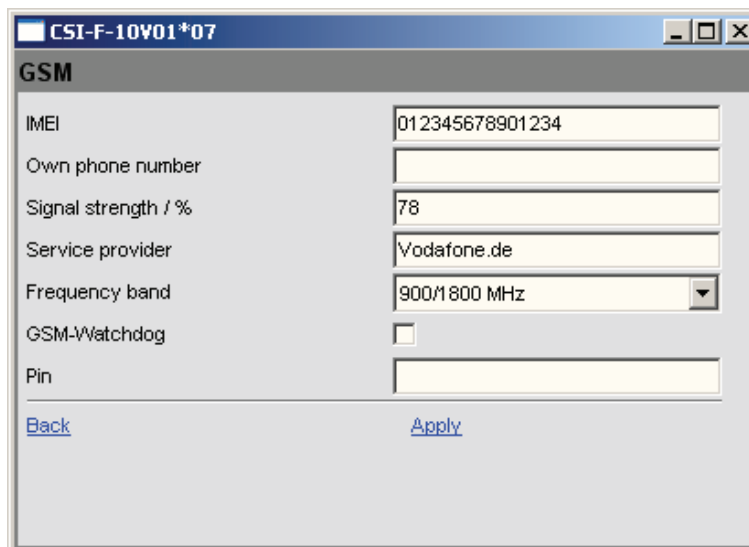

Click on "**Apply**", to apply the settings. "**Back**" takes you back to the main menu.

* The GSM watchdog function permanently checks for CSI-F-10 registration in GSM networks. If CSI-F-10 is found not registered for 15 min. then the GSM watchdog triggers a reset. After this the CSI-F-10 restarts and attempts GSM network registration again. In doing so the user program is also restarted. Possibly previously stored state of data are reset to default settings.

** Inputting the PIN code is only necessary if the PIN request is not activated on the SIM card. To deactivate the PIN code place the SIM card in a mobile telephone and follow the device menu to deactivate the PIN request!

- **Permissions**

Number [input telephone number with country code]
Text [allow written access]

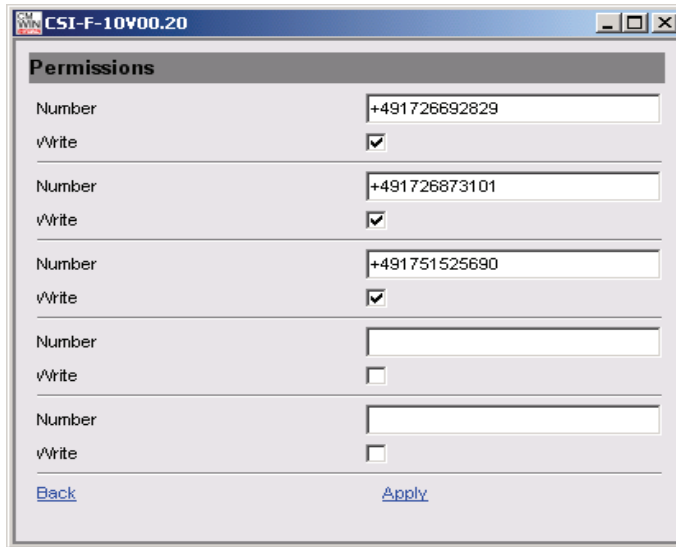

You can input up to five telephone numbers which allow connection to the CSI-F-10 and from which the device may receive enquiry text messages (SMS). By placing a checkmark in the "**Text**" box, you are also allowing access by text to the CSI-F-10 from this telephone number (change settings, transfer CM program, update firmware, ...)

Click on "**Apply**", to apply the settings. "**Back**" takes you back to the main menu.



Warning!

If no telephone numbers are input here, no subsequent communication via a GSM mobile radio connection can take place.

7.1.4.2 Information

- **General**

Supply voltage / V [displays value of supply voltage]
Sensor 'a' [displays type sensor 'a']
Sensor 'b' [displays type sensor 'b']
Note [input descriptive note]
Write authorization [displays whether programming enable is set] (see Chap. 6.2 Programming enable)

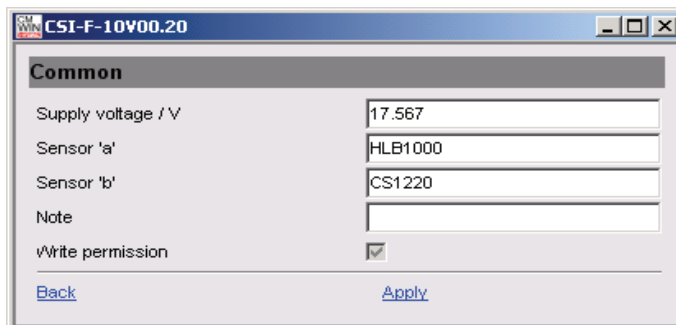

Click on "**Apply**", to apply the settings. "**Back**" takes you back to the main menu.

7.1.4.3 CM Program

- **Program**
CM Program / Byte [accumulator requirement display in CM program]
CM Source text / Byte [accumulator requirement display in CM source text]
Active [displays whether a CM program is active]

"**Back**" takes you back to the main menu.

- **Numerical input values**
 Here you can change the values of all the numerical input values used in the CM program.

Click on "**Apply**", to apply the settings. "**Back**" takes you back to the main menu.

- **Boolean input values**
 Here you can change the status of all the Boolean input values used in the CM program.

Click on "**Apply**", to apply the settings. "**Back**" takes you back to the main menu.

7.1.5 Managing Configurations

Here you can generate and manage various configuration files. These configuration files can, for example, be generated in series on a "Master" device and then loaded on an unlimited number of other CSI-F-10.

The following configuration files can be generated and managed:

- Input values
- Information
- Permissions
- Program
- GSM
- Date / Time

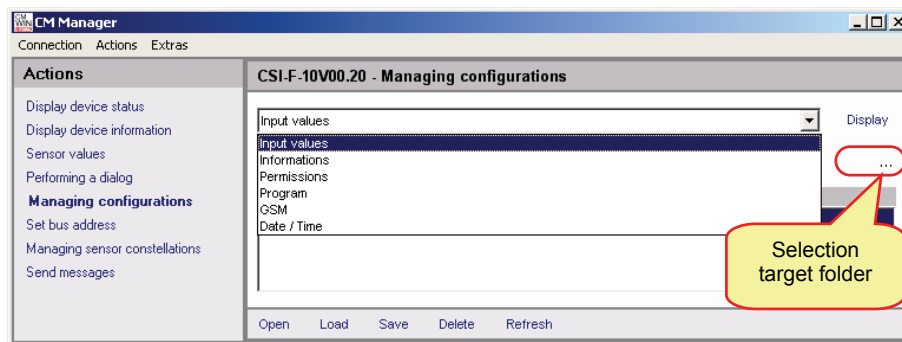

- With **Open** you can display the contents of a configuration file listed in the lower display field. Highlight the required file with a mouse click. You can print out the file in the window that opens automatically.
- With **Load** you can transfer a configuration file (marked in the lower display field) from the PC to the CSI-F-10. The following message appears after the completion of the transfer:

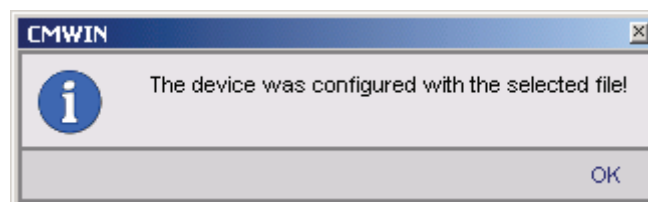

- When you press **Save**, you generate a new configuration file or save a modified one to the previously specified target folder.
- Press **Delete** to delete the configuration file in the target folder highlighted in the lower display field.
- Press **Refresh** to update the display field for the configuration files. The specified target folder will be selected again for this purpose. This is necessary, e.g. when you copy or delete configuration files using Windows Explorer. These changes will not be displayed in the folder until after "Refresh" has been carried out in CMWIN.
- With **Display** you can display the particular "Actual Configuration" currently in the connected CSI-F-10.

7.1.6 Set bus address

The **Set bus address** function is a general CMWIN function, but which cannot be used on a CSI-F-10 GSM radio module which is directly connected. A CSI-F-10 directly connected to a PC generally has the address "**Bus master**", which cannot be altered.



Warning!

If you try to change the bus address of the CSI-F-10, an error message appears.

7.1.7 Managing sensor constellations

The sensor constellation is a monitoring instrument for the connected sensor system, i.e. it continually compares the connected "Actual" sensor system with the specified "Target" sensor system (see Chap. 8.1.5. Sensor constellation).

You can use this function to generate and manage various sensor constellation files. These constellation files can, like the configuration files, be generated on a "Master" device and then loaded onto an unlimited number of other CSI-F-10.

If no sensor constellation has yet been generated in the device then the following window opens:

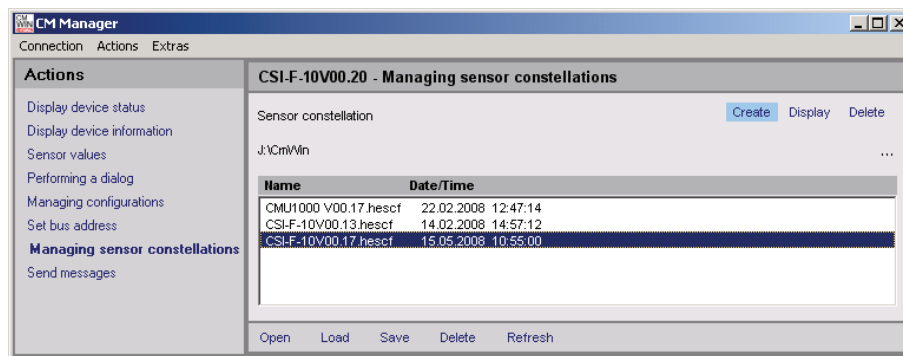

- You can generate a new sensor constellation in the device by pressing **Create** (in the upper command bar). Afterwards, the following message appears:



- Press **Display** (in the upper command bar) to display the actual sensor constellation currently in the device.
- Press **Delete** (in the upper command bar) to delete the actual sensor constellation currently in the device.

All other functions in the lower command bar (Open, Load, Save, Delete, etc.) and the selection of the target folder for saving the files are identical with Chapter 7.1.5 "Managing configurations".

7.1.8 Sending a text message

The "**Send text message**" serves mainly to test the GSM mobile radio connection.

- In the **Telephone number** field, input the required number (this is independent of the telephone numbers in Chap. 7.1.4.1 Permissions).
- In the **Message** field, input the message text.

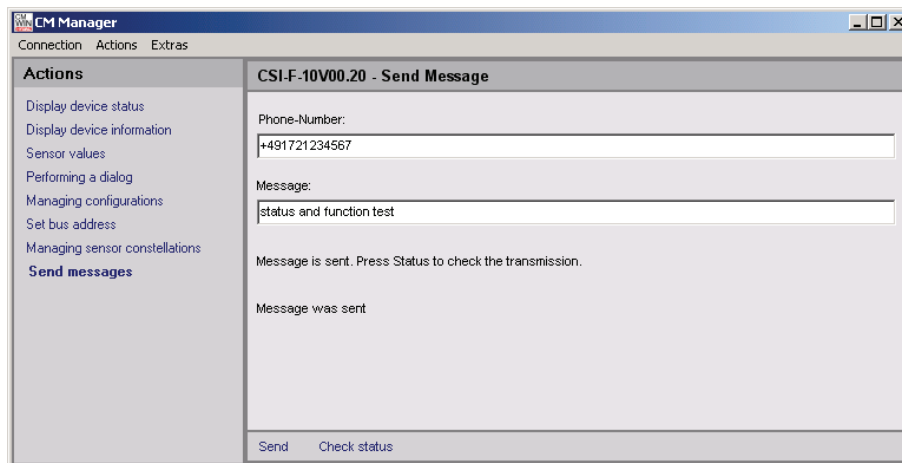

- Click "**Send**" to send the message.
- By clicking on "**Check status**" you can track the progress of the message transfer and check the connection.



Warning!

Text messages cannot be sent if the CSI-F-10 is being accessed via GSM connection. This function is only available with cable connection (e.g. connection via CSI-B-2, HMG 510, CMU 1000).

7.2 Extras

7.2.1 Update Firmware



Caution

The voltage supply to the CSI-F-10 must not be interrupted during the firmware update. If the voltage supply fails during the update process, then trouble-free functioning can no longer be ensured and the device must be returned to HYDAC SERVICE GMBH.

- After selecting this menu option, you can update the firmware of your CSI-F-10. The following window opens for this purpose:

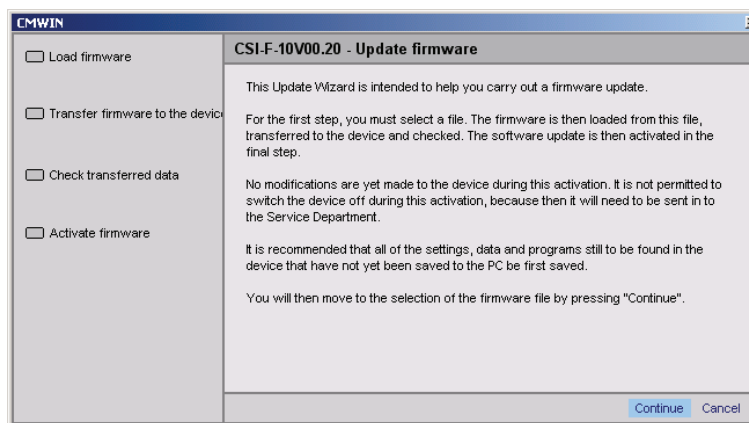

- Follow the instructions and confirm with **Continue**. In the window that opens, select the corresponding Update file and click on **Open**.

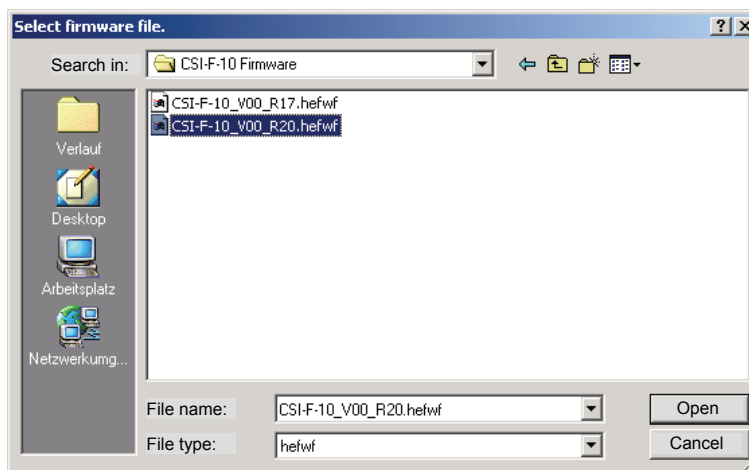

- Follow the instructions in the following window:

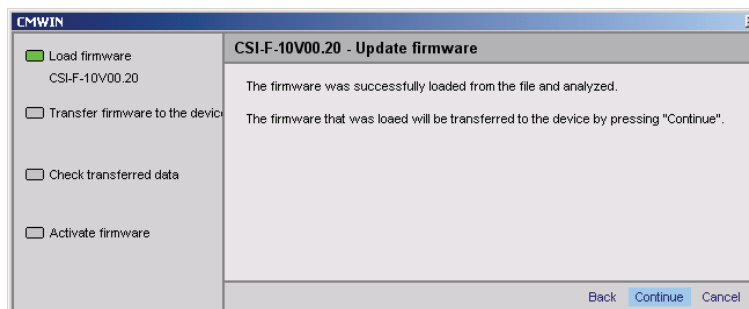

- Confirm with **Continue** to transfer the data to the CSI-F-10.

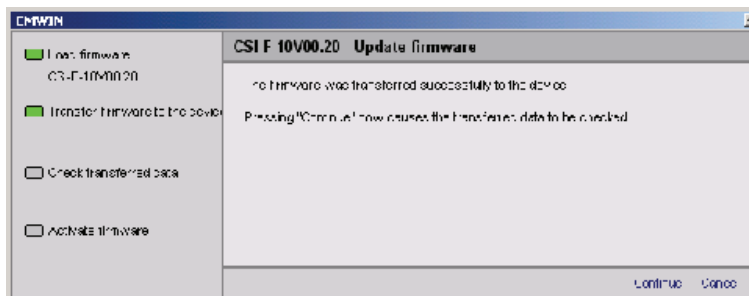
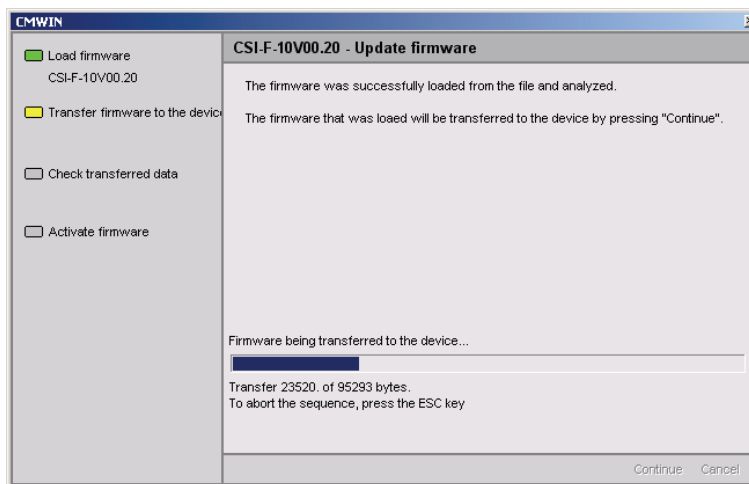

- By confirming with **Continue**, the data in the CSI-F-10 will be checked, and the following two windows will appear one after the other:

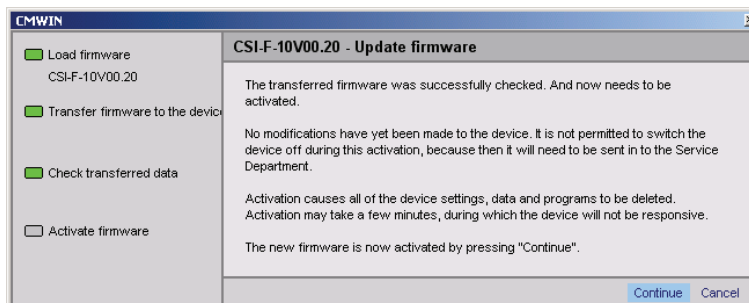
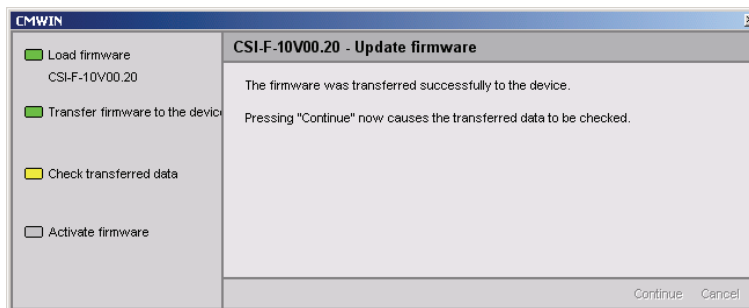

- Confirm again with **Continue** to activate the new firmware in the device.

- In CMWIN the following window is the last one to open. Click on **Close** to return to the CM Manager.
Afterwards, the CSI-F-10 reboots with the updated firmware. This breaks the connection and this must be restored.

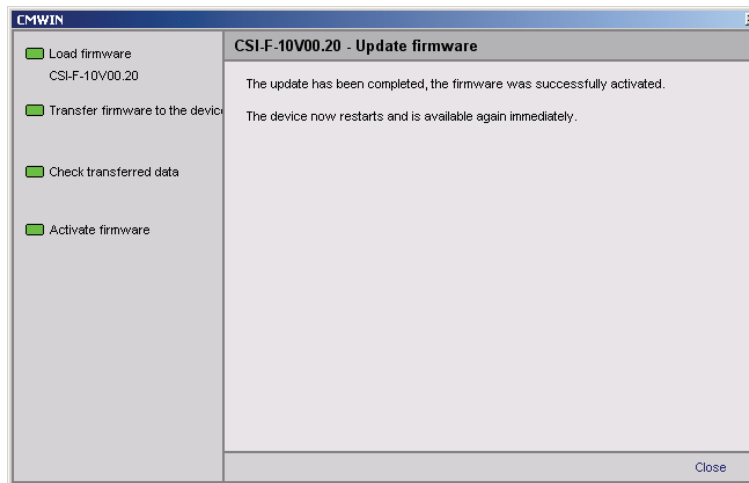
**Note!**

All settings, configurations, constellations and the CM program are retained and not overwritten when the firmware is updated.

8 CM Editor

The CSI-F-10 GSM radio module processes its program in continuous cycles. You generate the program with the **CM Editor** then load it into the device.

The CM Editor is a constituent part of the HYDAC PC software **CMWIN**, Version 3 or higher, and provides you with various tools and functions for designing, integrating and testing your CM program.

To open the Editor, proceed as follows:

- Start the HYDAC PC software **CMWIN**
- In the **Extras** Menu, select the "CM Editor" option.

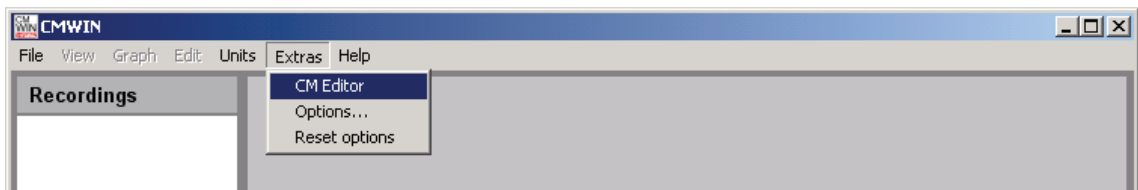

- The following screen opens:

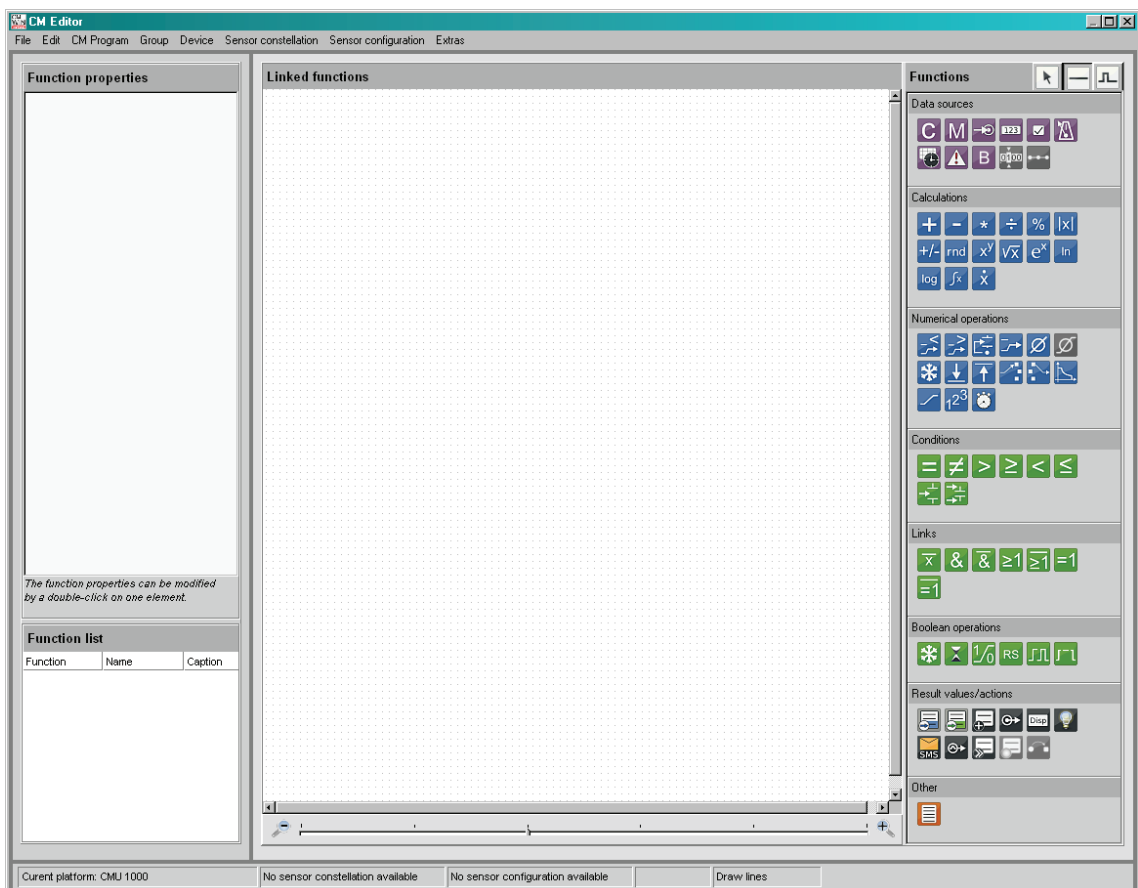

The menu structure and window properties of the Editor are explained below in greater detail:

8.1 Menu Bar

The menu bar of the CM Editor is tailored to the MS Windows user interface and contains the following menu structure:

8.1.1 File

- With "**New**", you can establish for which platform (CM device) the CM program is to be created before starting to create the CM program. The program functions which are not available for the selected platform will be grayed out in the **Functions** window and cannot be used during program generation.
- With "**Platform**", you can establish for which platform (CM device) the CM program is to be created during the creation of a CM program. The program functions which are not available for the selected platform will be grayed out in the **Functions** window and cannot be used during program generation.
- Pressing "**Open**" allows you to open an already generated and stored CM program. CM programs have the file extension ***.hecmp**. Select the required file in the corresponding path.
- Select "**Save**" to save a CM program. If the recording has not yet been saved, the "**Save as...**" window will open. Enter the required file name in the corresponding path.
- To save a file that has not yet been saved or to save a file that has already been saved under a different name, select "**Save as ...**". Enter the required file name in the corresponding path.
- To integrate an existing program that has already been saved into the current program generation process, select "**paste from file**". Select the required file in the corresponding path.
- Press "**Print**" to print out the content of the **Linked functions** window (= program printout).
- Press "**Exit**" to close the CM Editor.

8.1.2 CM Program

- After "**Display**" is selected, a window opens listing all the functions used in the CM program which is currently open, together with inscriptions and parameters. The list can be printed out by selecting "**Print**". Click on "**Close**" to take you back to the CM Editor.

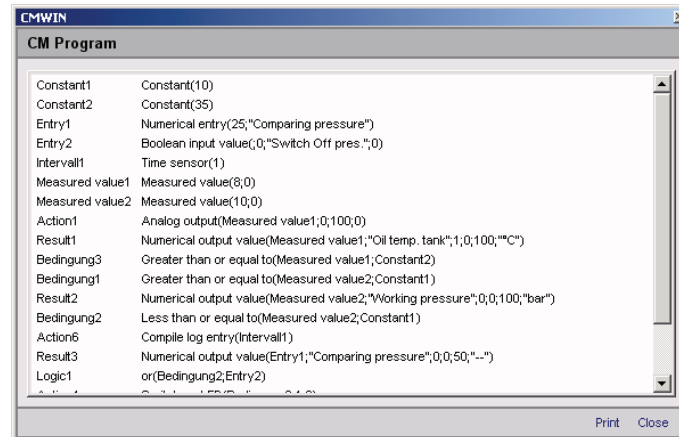

- With "**Simulate**", you can simulate and/or test the CM program that is currently open. The **Simulation** window opens for this purpose. It is not necessary for the CSI-F-10 to be connected for the simulation.

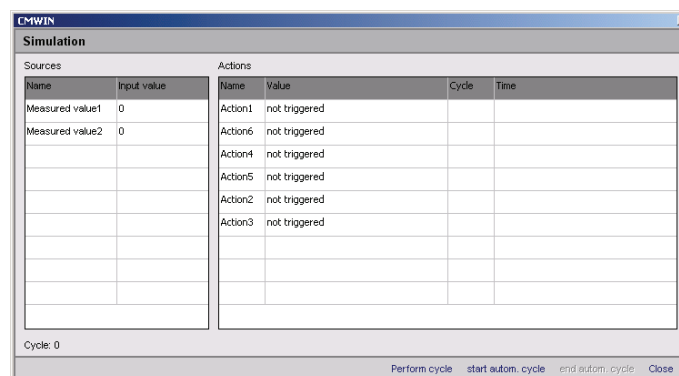

- All of the input signals used in the CM program are listed one below the other in the **Name** column in the left-hand part of the Simulation window.
- You can assign a specific value to each input in the **Input value** column.
- All of the actions used in the CM program are listed one below the other in the **Name** column in the right-hand part of the Simulation window.
- The current status of each action is displayed in the **Value** column.
- The cycle number of the last status modification is displayed in the **Cycle** column.
- The date and time of the last status modification is displayed in the **Time** column.

- With **"Perform cycle"**, you can start the simulation for a single processing cycle and view the resulting status modifications of the actions afterwards.
- With **"Start autom. cycle"** you can start a permanent, continuous program simulation. You can change the input values however you like during the simulation and observe the status modifications of the actions.
- With **"End autom. cycle"** you can stop the permanent, continuous program simulation.
- Click on **"Close"** to take you back to the CM Editor.

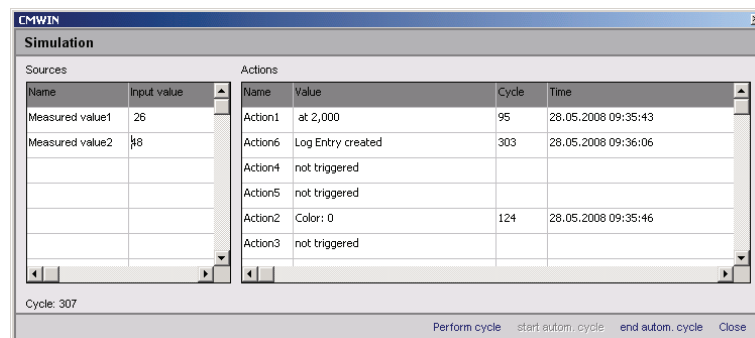

- During the simulation, the assigned input values and action statuses are also displayed in the **Linked Functions** window by means of corresponding symbols.

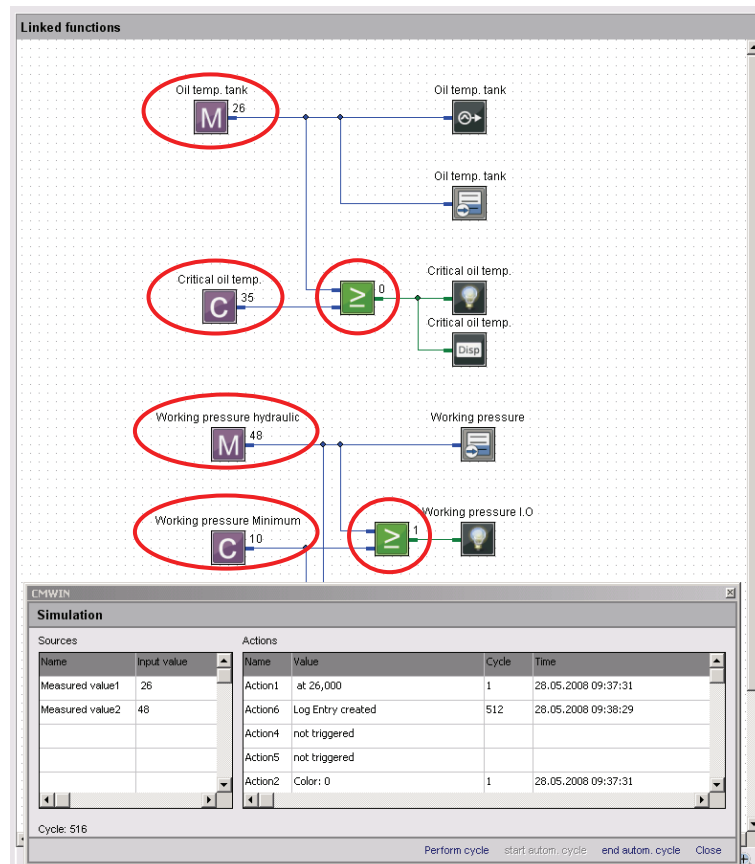

- You can transfer the currently opened CM program to the CSI-F-10 with **"Transfer into device"**.

**Note!**

Only error-free programs can be transferred into the CSI-F-10.

- The following message appears after the program has been successfully transferred:

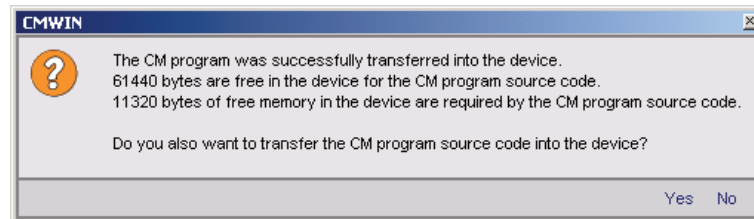

- Here you can select whether you also wish to transfer the source code of the program into the CSI-F-10.

**Note!**

If the source code is also transferred into the CSI-F-10, then it is possible for it to be read again by every other connected PC and modified! If the source code is not also transferred into the CSI-F-10, then the program cannot be uploaded by another PC.

- The following message will appear if the CM program contains errors when attempting transfer:

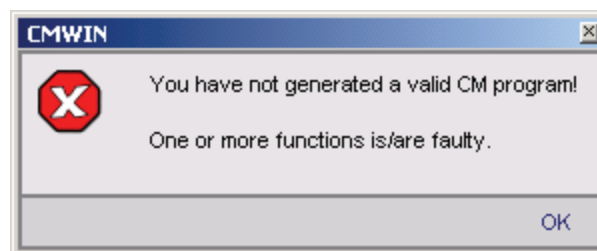

- Eliminate the error(s) found in the CM program (see Chap. 8.2.2 "Function list" window and Chap. 10. "Error messages") and transfer the program again.

**Note!**

If you transfer a program and a power failure occurs during the transfer, then the program will not be saved in the CSI-F-10 after power is restored. For that reason, first save your program on the PC on which it was originally generated or modified before making the transfer.

- You can transfer and then edit the CM program currently available in the CSI-F-10 to your PC with "**Receive from device**". This will however only work if the CM program source code from the original creator has also been transferred into the CSI-F-10.
If no source code is available in the CSI-F-10, then the following message will appear:

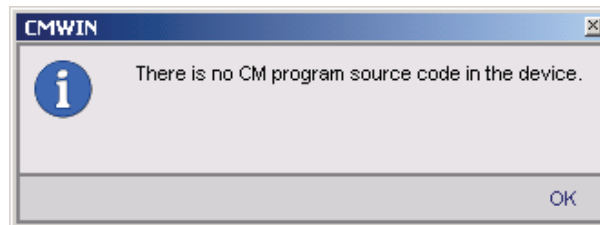

- The "**Online Debugging**" function is a tool for observing the CM program as well as for finding, diagnosing and eliminating possible errors in the CM program and/or in the connected peripherals.
 - The following prerequisites must be fulfilled for this purpose:
 - The CSI-F-10 must be connected with the PC and the CMWIN software.
 - The CM program opened in CMWIN and the one active in the CSI-F-10 must be identical.
 - If the "Online Debugging" mode is active, then the following values will be displayed for the relevant functions:
 - Measured values
 - Constants
 - Switching status of logical links
 - Date and time when initiating the corresponding event
 - The display in "Online Debugging" mode is shown in the following illustration, by way of example:

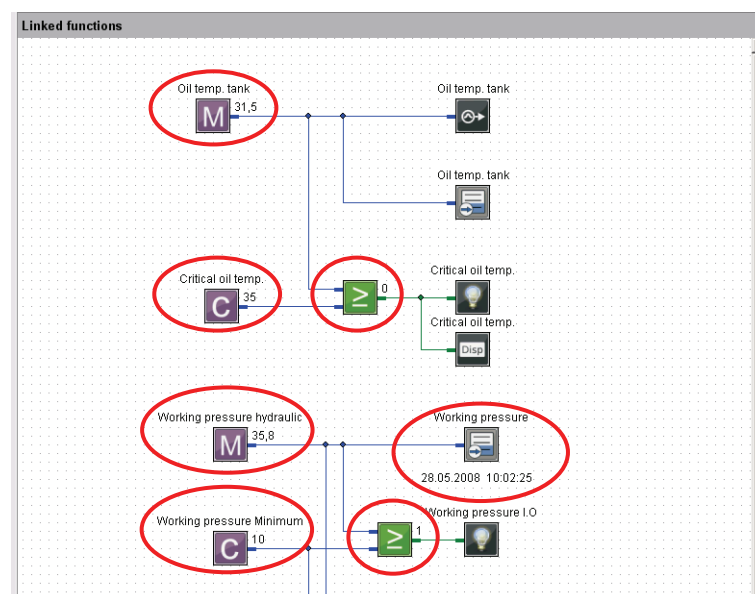

8.1.3 Grouping

- With **Create grouping** you can join several functions to make an cohesive unit and move and copy these as a block.
 - First mark the functions to be grouped by enclosing them in a frame drawn with the help of the cursor.
 - Afterwards, select “Group” in the menu bar and then “Create grouping” in the drop-down menu that appears.

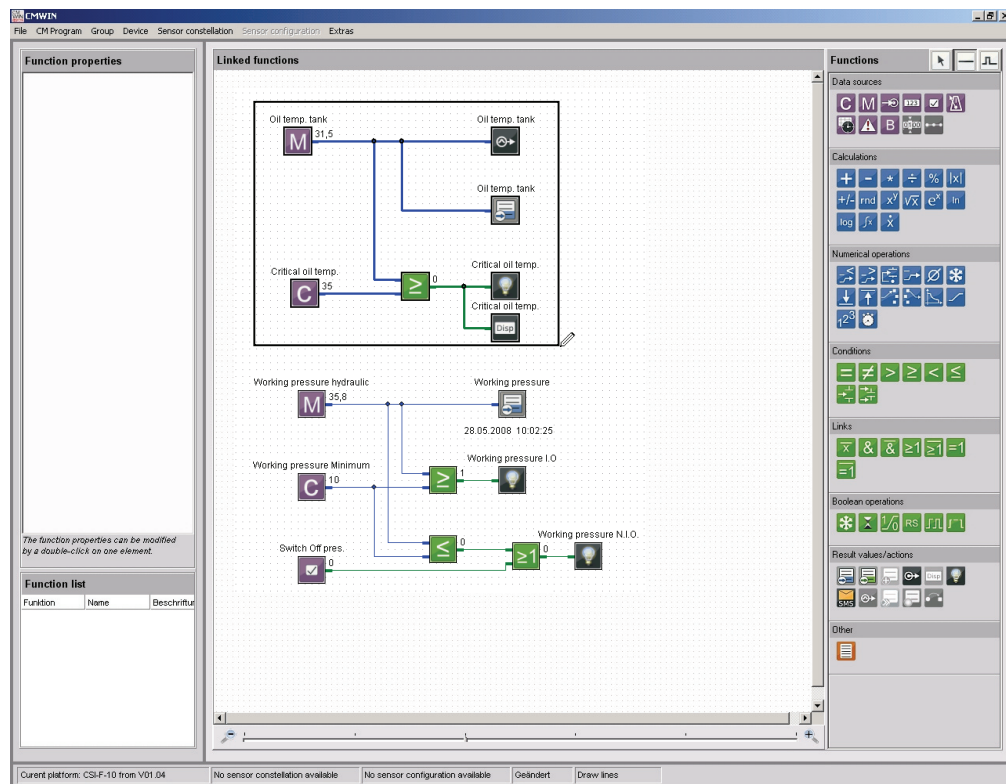

- Click on **Cancel grouping** to ungroup the functions which were linked together in the group.
 - To do this, highlight the group concerned by clicking on any one of the functions within the group.
 - Afterwards, select “Group” in the menu bar and then “Cancel grouping” in the drop-down menu that appears.

8.1.4 Device

The “**Connection**” function can be used to set up a connection between the PC and a CSI-F-10 from the CM Editor.

The function is identical with the connection setup in the CM Manager. See Chap. 6.3.2 ff.

8.1.5 Sensor constellation

For reliable system monitoring, ensure that exactly the same sensors that were connected at the time the CSI-F-10 was configured are connected during operation.

The **Sensor constellation** is used for this purpose. The sensor constellation is a monitoring instrument for the connected sensor system, i.e. it continually compares the connected "Actual" sensor system and the specified "Reference" sensor system.

The sensor constellation is optional in the CSI-F-10 and not compulsory. If however a sensor constellation has been saved, then the connected sensor system must match it. When there is an activated sensor constellation, then an "incorrect" sensor connected by mistake will be recognized, thus preventing a situation in which the CM program is working with incorrect information.

A sensor constellation can be saved in files and loaded from files, and can be both received and transferred by the CSI-F-10.

The constellation files all have the extension ***.hescf**.

The sensor constellation contains the following data:

- Quantity of connected sensors
- Quantity of subchannels for each connected sensor
- Status of each individual subchannel (active/inactive)
- Sensor class (analog / HSI / SMART)
- Units of the individual measured values
- Name of each sensor
- Device designation of each sensor

If a sensor constellation is available in the CM Editor, then you can use the correct names in connection with the measurements during program generation. It will then be the case that only those sensors and subchannels that are actually present will be available and accessible for adjustment.

A status message at the lower edge of the window of the CM Editor indicates whether or not a sensor constellation is available.

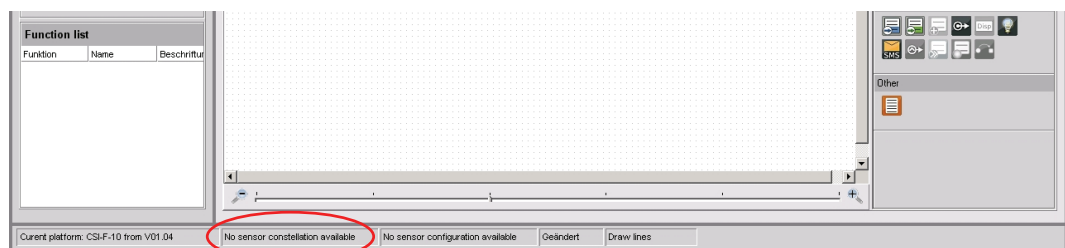

- With the function **Apply from file**, you can open a saved sensor constellation file and use it in the CM Editor.
To do this, enter the corresponding path and file name in the window that opens and then click on **Open**.
- With the function **Apply from device**, you transfer one of the sensor constellations stored in the CSI-F-10 to your PC, after which you can use it in the CM Editor.

- With **Uninstall** you delete the currently available sensor constellation in the CM Editor, after which it is no longer available for further use when generating programs.
No saved constellation files are deleted!
- To save a constellation file, select **Saving to file**. Enter the appropriate path and required file name for this purpose in the window that opens.
- When the **Display** function is selected, a window opens in which the complete sensor constellation is displayed.

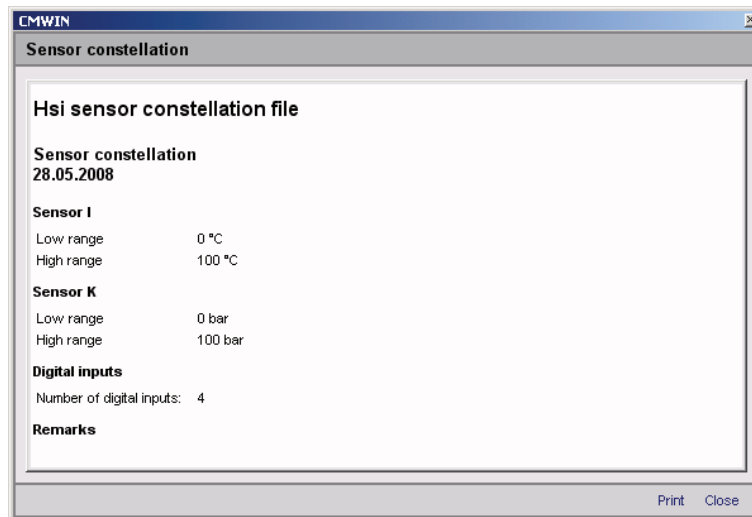

8.1.6 Extras

- The following window opens when the function **Options** is selected:
The selection buttons at the right-hand edge of the window appear after clicking in the respective selection field.

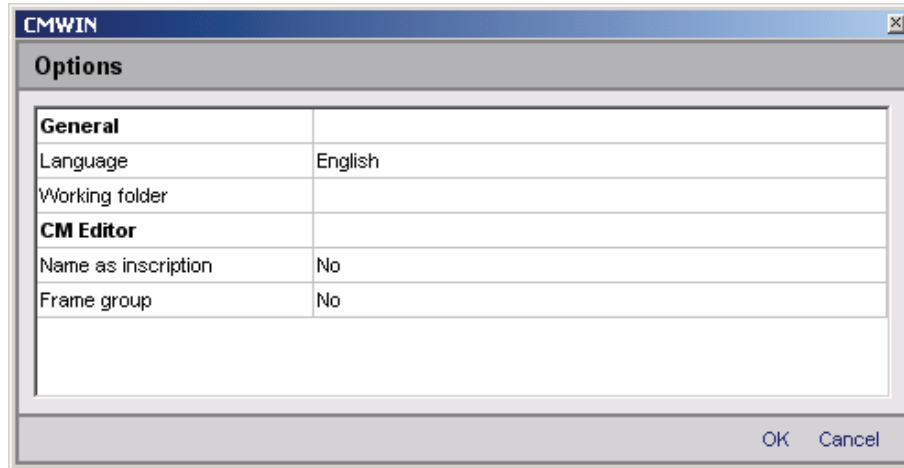

- In the **Language** field, you can select either German, English or French as the CMWIN system language.
 - In the field **Working folder** you define the path for saving the CMWIN files (CM programs, recordings, constellation and configuration files, ...).
 - In the field **Name as inscription** you define whether or not the particular function name (e.g. Measured value 2, Action 4) is to be displayed as the function inscription in the "Linked functions" window.
If "No" is selected, then you have the option of entering an inscription text manually into the function parameters.
 - In the field **Frame group** you define whether or not a frame is to be shown around generated groups in the CM program.
 - Clicking on **OK** applies the settings and returns you to the main CMWIN window.
Pressing **Cancel** takes you back without applying any changes.
- By using the **Reset Options** function you can reset all the modified options and settings to the standard settings.
 - Select the **Display cycle time** function to open the following window and to display the current cycle time of the CM program.

Example:

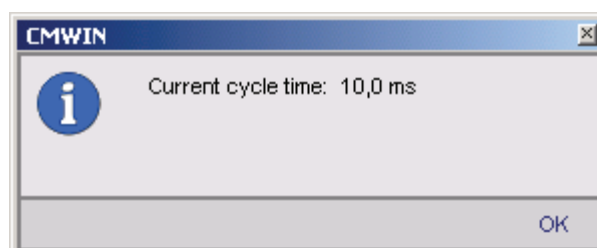

8.2 Window Divisions

The graphics interface of the CM Editor is divided into the following elements:

8.2.1 "Function Properties" Window

The properties of the functions currently selected in the CM program are displayed in this window. These include:

- Function name (e.g. Action 2; Constant 5; Measured value 12)
- Function type (e.g. Constant, Measured value, Time Sensor)
- Specific properties (parameter settings)
- Comment

8.2.2 "Function List" Window

This window lists all the functions used in the CM program with the following specifications:

- Function type (e.g. Constant, Measured value, Time sensor)
- Function name (e.g. Action 2; Constant 5; Measured value 12)
- Inscription (e.g. Working pressure N.O.K.)

8.2.3 "Linked Functions" Window

This window contains the actual CM program. The display can be zoomed in or out with the scroll bar on the lower edge of the window.

8.2.4 "Functions" Window

This window contains all the functions available for program generation, sorted according to:

- Data sources
- Calculations
- Numerical operations
- Conditions
- Links
- Boolean operations
- Result values/actions
- Other

9 CM Program Functions

A CM program consists of many individual functions that are linked with one another and that are processed and evaluated cyclically.

9.1 General Information Concerning Functions

A function has *Inputs*, *Outputs* and *Parameters*. This means, for example, the function "Median value" reads a numerical value at the input, forms a median value above it and then displays this at the output. A parameter is used to define the amount of time for which the calculation is rendered.

9.1.1 Inputs / Outputs

For most functions, the outputs change during the running time, depending on the input. Functions are linked with one another in the Editor. This means, for example, that the output of a function can be linked with the input of a different function. It is possible to make one output dependent on several inputs, but not several outputs on one input.

There are two types of inputs/outputs, depending on the value type: *Numerical* and *Boolean*. A "Boolean output" can only be linked with a "Boolean input" and a numerical output can only be linked with a "numerical input".

9.1.1.1 Numerical Values

A numerical value is a decimal number, i.e. a numerical value with an optional plus/minus sign and any number of digits after the decimal point. It is accurate to 7-8 significant places. That means that with a value of 2 million (7 places in front of the decimal point), the addition of a value of 0.001 (3 places after the decimal point) will not alter the numerical value. One would need accuracy to at least 10 significant places for it to be altered.

Numerical inputs/outputs and the corresponding connection lines are shown in **blue**.

9.1.1.2 Boolean Values

A Boolean value is a logical status. There are only 2 statuses: "true" or "1" and false or "0".

Boolean inputs/outputs and the corresponding connection lines are shown in **green**.

9.1.2 Parameters

Parameters are defined in the Editor and do not change during the running time. Exceptions to this are the input parameters which can be modified during the running time in a menu on the CSI-F-10 or using a PC which is connected.

Parameters have one of the following types:

9.1.2.1 Numerical Parameters

A numerical parameter is a decimal number in accordance with the inputs/outputs.

9.1.2.2 Whole Number

A whole number is a natural number, i.e. it has no digits after the decimal point. As a rule, no negative numbers are permitted either. Whole numbers are used for example for numbering purposes.

9.1.2.3 Input List

An entry from a list is selected for the input list type. The quantity and the type of list entries is dependent on the particular parameter.

9.1.2.4 Boolean Parameters

A Boolean parameter has, as already described in connection with the inputs/outputs, only two logical statuses: "0" and "1". Nevertheless, it is not "0" and "1" that are set in the Editor, but rather such terms as "No" or "Yes", "Inactive" or "Active", "Off" or "On", depending on the context.

9.1.2.5 Character String

A character string is an arbitrary text, the length of which is usually limited. In addition, any leading and subsequent empty spaces are usually removed automatically.

9.1.2.6 Values Table

A values table is a table with several values, whereby each value is positioned in a line of its own.

Furthermore, it is also possible to enter value pairs. The individual values of a value pair are then separated from one another with a colon ":".

9.1.2.7 Time of day

The time of the day is specified in the country-specific format that is set in Windows.

9.2 Data Sources

9.2.1 Numerical Constant



The *Numerical Constant* function supplies a numerical value which is defined in the Editor and which does not change during the running time.

That means that the *Value* parameter entered in the Editor is output during the running time at the output.

Inputs: -
 Outputs: y: (Numerical)
 Parameters: p₁: Value (Numerical)

9.2.2 Measured value



The *Measured Value* function provides the current measured value of a connected sensor.

The *Sensor connection* parameter is used to define the sensor; the channel of the sensor with *Subchannel*. If a connected sensor has no subchannel, then no selection is possible at this point.

If a sensor constellation has been saved, then only the active connections are displayed in the input lists for the *Sensor connection*, each of them with the relevant sensor name. The subchannels available for this sensor are then displayed at *Subchannel*, each of them with name and unit.

If no sensor constellation is saved, then Ports "A" to "P" are offered for selection at *Sensor connection* and Channels "1" to "32" at *Subchannel*.

Inputs: -
 Outputs: y: (Numerical)
 Parameters: p₁: *Sensor connection* (input list)
 p₂: *Subchannel* (input list)

9.2.3 Digital Input



The *Digital input* function supplies the status of a digital input.

The *Input terminal* parameter is used to define which digital input port is used.

Inputs: -
 Outputs: y: (Boolean)
 Parameters: p₁: *Input terminal* (input list)

9.2.4 Numerical Entry



The function *Numerical input* supplies a numerical value which can be adjusted in the Parameters menu of the CM device. As an alternative, it can also be set via a connected PC.

The *Inscription* parameter is used as a menu option in the input menu for this purpose. The permitted input range runs from -2,000,000.000 to +2,000,000.000.

Changes which are carried out in the CM device during running time are retained even after the device is switched off. Once the CM program is transferred into the CM device for the first time, the value set under *Start value* is used until the first change.

Inputs: -
 Outputs: y: (Numerical)
 Parameters: p₁: *Starting value* (Numerical)
 p₂: *Inscription* (character string)

9.2.5 Boolean Entry



The *Boolean input* function supplies a Boolean value, which can be set in the Parameters menu of the CM device. As an alternative, it can also be set via a connected PC.

The *Inscription* parameter is used as a menu option in the input menu for this purpose. Input is accomplished on the CM device by selecting "Yes" or "No".

Changes which are carried out in the CM device during running time are retained even after the device is switched off. Once the CM program is transferred into the CM device for the first time, the value set under *Start value* is used until the first change.

The *Functionality* parameter defines how the input is interpreted. The following settings are possible:

Switch

A menu option is generated on the CM device with which the input value can be switched on or off. This functionality is used to activate certain paths in the evaluation logic.

Key

When the value on the CM device is switched on, then only one impulse is generated in the evaluation logic and the option switches itself off in the menu again immediately. A key function is simulated, so to speak. This functionality can be used to trigger events in the evaluation logic.

Inputs: -
 Outputs: y: (Boolean)
 Parameters: p₁: *Starting value* (Boolean)
 p₂: *Inscription* (character string)
 p₃: *Functionality* (entry list)

9.2.6 Time Sensor



The *Time sensor* is a function which generates a pulse at an adjustable interval (e.g. every minute, every 5 minutes), thus setting its Boolean output to "1" for a cycle and then back to "0".

The following settings are possible for the *Interval* parameter:

- 1; 2; 5; 10; 15; 30 Seconds,
- 1; 2; 5; 10; 15; 30 Minutes,
- 1; 2; 6; 12; 24 Hours.

At the same time the output pulse is always synchronized with the time of day. If, for example, "6 hours" is set, then a pulse will be generated at 0600 HRS, 1200 HRS, 1800 HRS and 2400 HRS.

If a pulse is required at particular times of the day, then you should use a clock timer with a downstream pulse generator instead of a time sensor (see Chap. 9.8.6).

Inputs: -
 Outputs: y: (Boolean)
 Parameters: p₁: *Interval* (input list)

9.2.7 Clock Timer



The *Clock timer* is a function which switches on its Boolean output at a certain time during a month and then switches it off again at a different point in time.

The switch-on time is set using the parameters *Switch-on day* and *Switch-on time*, while the switch-off time is set using the parameters *Switch-off day* and *Switch-off time*.

A weekday "Monday" to "Sunday" can be set. The setting "Daily" is also possible. The "Daily" setting is only possible if both days are set to "Daily". The Editor prevents erroneous inputs: If, for example, the switch-on day is changed from "Monday" to "Daily", then the switch-off day is automatically set to "Daily".

If switch-on time and switch-off time are identical, then the output will be switched on for precisely this specified second.

If only one pulse is required, i.e. if the output is intended to be set for exactly one cycle to "1" and then back to "0", then use a downstream pulse generator (see Chap. 9.8.6).

Inputs: -
 Outputs: y: (Boolean);
 Parameters: p₁: *Switch-off day* (input list)
 p₂: *Switch-off time* (time of day)
 p₃: *Switch-on day* (input list)
 p₄: *Switch-on time* (time of day)

9.2.8 Error Event



Error handling can be implemented with the function *Error event*. The Boolean output is switched to "1" when an error condition is present. The output is switched back to "0" if the error disappears.

The type of error event can be set with the *Event* parameter.

The following events are possible:

Below *signal* *range*
A sensor has a cable break, for example

Above *signal* *range*
The signal of one sensor is above the signal range

Incorrect sensor constellation

There is either no sensor, or an incorrect sensor connected to one sensor connection port.

Numerical error

An error occurred during a calculation, e.g. division by 0 or square root of a negative number, logarithm of 0, etc.

Cycle *time* *exceeded*
The set cycle time was exceeded.

Inputs: -
Outputs: y: (Boolean)
Parameters: p₁: *Event* (input list)

9.2.9 Boolean Constants



The Boolean Constant function supplies a Boolean value which is defined in the Editor and which does not change during the running time. That means that the parameter entered in the Editor is output during the running time at the output.

Inputs: -
Outputs: y: (Boolean)
Parameters: p₁: Value (Boolean)

9.3 Numerical Calculations

9.3.1 Addition



The *Addition* function returns the sum of the two input values at the output:

$$y = x_1 + x_2$$

Inputs: x_1 : (Numerical)
 x_2 : (Numerical)
Outputs: y : (Numerical)
Parameters: -

9.3.2 Subtraction



The *Subtraction* function returns the difference between the two input values at the output:

$$y = x_1 - x_2$$

Inputs: x_1 : (Numerical)
 x_2 : (Numerical)
Outputs: y : (Numerical)
Parameters: -

9.3.3 Multiplication



The *Multiplication* function returns the product of the two input values at the output:

$$y = x_1 * x_2$$

Inputs: x_1 : (Numerical)
 x_2 : (Numerical)
Outputs: y : (Numerical)
Parameters: -

9.3.4 Division



The *Division* function returns the quotient of the two input values at the output:

$$y = x_1 / x_2$$

Inputs: x_1 : (Numerical)
 x_2 : (Numerical)
Outputs: y : (Numerical)
Parameters: -

9.3.5 Division Remainder



The *Division remainder* function returns the division remainder (the modulo) of the two input values at the output. The division remainder is determined by performing a whole number division x_1 / x_2 and outputting the remainder of this division as output value.

If the input x_1 counts upward, e.g. sequentially by 1, and the input x_2 is 5, then the output will count around from 0 to 4.

Inputs:	x_1 :	(Numerical)
	x_2 :	(Numerical)
Outputs:	y :	(Numerical)
Parameters:	-	

9.3.6 Absolute Value



The *Absolute value* function returns the input value without a plus/minus sign at the output:

$$y = |x|$$

Inputs:	x :	(Numerical)
Outputs:	y :	(Numerical)
Parameters:	-	

9.3.7 Change of Algebraic Sign



The *Change of sign* function returns the inverse input value at the output:

$$y = -x$$

Inputs:	x :	(Numerical)
Outputs:	y :	(Numerical)
Parameters:	-	

9.3.8 Rounding



The *Rounding* function returns the rounded input value at the output. With this function, it is possible not only to round to whole decimal places, but also to whole-number multiples of a step.

The size of the step is specified in the *Step* parameter.

If the step size is 20, for example, then all values between -10 and 10 will be rounded off to 0, all values between 10 and 30 to 20, and so on.

Inputs:	x :	(Numerical)
Outputs:	y :	(Numerical)
Parameters:	p_1 :	<i>Step</i> (Numerical)

9.3.9 Raising to a Higher Power



The *Raising to a higher power* function supplies the power of the input value at the output.

The exponent is set using the *Exponent* parameter.

Inputs:	x:	(Numerical)
Outputs:	y:	(Numerical)
Parameters:	p ₁ :	<i>Exponent</i> (Numerical)

9.3.10 Square Root



The *Square root* function supplies the square root of the input value at the output.

If the input value is negative, then the value 0 will be supplied at the output and an error flag will be set. One can react to this situation with the *Error event* function (see Chap. 9.2.8).

If it is possible for a negative input to occur in practice, then you should structure the corresponding behavior in accordance with your preferences with the functions *Absolute value*, *If-then-else* and *Less than* (see Chap. 9.3.6, 9.4.4 and 9.6.5).

Inputs:	x:	(Numerical)
Outputs:	y:	(Numerical)
Parameters:	-	

9.3.11 Power at Base e



The *Power at base e* function supplies the power at base e at the output.

The input value is used as the exponent.

Inputs:	x:	(Numerical)
Outputs:	y:	(Numerical)
Parameters:	-	

9.3.12 Natural Logarithm



The *Natural logarithm* function supplies the logarithm of the input value at base e at the output.

If the input value is negative or 0, then the value 0 will be supplied at the output and an error flag will be set. One can react to this situation with the *Error event* function (see Chap. 9.2.8).

If it is possible for a negative input to occur in practice, then you should structure the corresponding behavior in accordance with your preferences with the functions *Absolute value*, *If-then-else* and *Less than* (see Chap. 9.3.6, 9.4.4 and 9.6.5).

Inputs:	x:	(Numerical)
Outputs:	y:	(Numerical)
Parameters:	-	

9.3.13 Decade Logarithm



The Decade logarithm function supplies the logarithm of the input value at base 10 at the output.

If the input value is negative or 0, then the value 0 will be supplied at the output and an error flag will be set. One can react to this situation with the Error event function (see Chap. 9.2.8).

If it is possible for a negative input to occur in practice, then you should structure the corresponding behavior in accordance with your preferences with the functions *Absolute value*, *If-then-else* and *Less than* (see Chap. 9.3.6, 9.4.4 and 9.6.5).

Inputs:	x:	(Numerical)
Outputs:	y:	(Numerical)
Parameters:	-	

9.3.14 Integral



The *Integral* function supplies the integral of the input value over time at the output. The output is always calculated with the unit of seconds. This means that the input value 6 causes the output to increase every second by 6. The trapezoidal rule is applied to make the calculation.

The function still has a Boolean reset input. If the value "1" is pending there, then the value "0" will be set up at the output.

Furthermore, the integral function also has an automatic anti-wind-up mechanism. It is with this that a parameterizable *Lower limit* and *Upper limit* are set for the output.

This function adopted from control engineering has the following background:

If a control variable is not achieved, then the I ratio continues to integrate further. The controller then may require under certain circumstances a very long time to exit this range again if the actuating variable reverses its sign. This can lead to very unstable behavior.

Inputs:	x_1 :	<i>Input value</i> (Numerical)
	x_2 :	<i>Reset input</i> (Boolean)
Outputs:	y:	(Numerical)
Parameters:	p_1 :	<i>Lower limit</i> (Numerical)
	p_2 :	<i>Upper limit</i> (Numerical)

9.3.15 Differential Quotient



The *Differential quotient* function supplies the derivation of the input value over time at the output. The output is always calculated with the unit of seconds. This means that an increase of the input value from 5 to 6 in one second will yield an output value of 1.

The differential quotient is formed and filtered numerically by the difference quotient. This filtering is necessary for the following reasons:

In view of the fact that the input values usually arise from a quantized measured value, e.g. in connection with the digitization of an analog quantity, these values will have a so-called quantization noise. This means that the digitization causes the value to fluctuate in terms of the resolution. For example, for 12 bit resolution, a value of 600 bar which has been expressed in 12 bit resolution, fluctuates back and forth by 0.15 bar. If the differential quotient is now generated every millisecond, this quantization noise is amplified by a factor of 1000. This means that, without filtering, the output would jump back and forth between + and - 150 bar/s.

The filter can be set with the *Filtering* parameter. The setting corresponds thereby to the time range during which the filtering takes place. However, a pure median value formation will not be used as a filter, but rather a special algorithm instead.

The following settings are possible:

- *switched off*, • *200 ms*, • *1 second* • *5 seconds*.

Inputs:	x_1 :	(Numerical)
Outputs:	y :	(Numerical)
Parameters:	p_1 :	<i>Filtering</i> (entry list)

9.4 Numerical Operations

9.4.1 Minimum



The *Minimum* function supplies the smaller of the two input values at the output.

Inputs: x_1 : (Numerical)
 x_2 : (Numerical)
 Outputs: y : (Numerical)
 Parameters: -

9.4.2 Maximum



The *Maximum* function supplies the larger of the two input values at the output.

Inputs: x_1 : (Numerical)
 x_2 : (Numerical)
 Outputs: y : (Numerical)
 Parameters: -

9.4.3 Limit



The *Limit* function limits the input value x_1 , and makes it available at the output.

The two limits are set by the input values x_2 and x_3 . If x_1 is less than x_2 , then x_2 will be output, if x_1 is greater than x_3 , then x_3 will be output, otherwise x_1 .

Inputs: x_1 : *Input value* (Numerical)
 x_2 : *Lower limit* (Numerical)
 x_3 : *Upper limit* (Numerical)
 Outputs: y : (Numerical)
 Parameters: -

9.4.4 If - then - else



The function *If-Then-Else* has two numerical inputs x_1 and x_2 as well as a Boolean input x_3 .

If the Boolean input value is "1", then the input value of x_1 is output at the output, otherwise the value of x_2 .

Inputs: x_1 : (Numerical)
 x_2 : (Numerical)
 x_3 : (Boolean)
 Outputs: y : (Numerical)
 Parameters: -

9.4.5 Median Value



The *Median value* function outputs the arithmetical median value of the input values over an adjustable time range.

The time range is set in seconds using the *Time* parameter.

The median value is formed according to the "Repeating Average" procedure. This means that, when the time setting is "2 seconds", for example, the input values are compiled for 2 seconds, then averaged and output at the output. The next median value interval begins after that. The output value pauses on the last median value.

Inputs:	x:	<i>Input value</i> (Numerical)
Outputs:	y:	<i>Median value</i> (Numerical)
Parameters:	p ₁ :	<i>Time</i> (Numerical)

9.4.6 Note Value



The *Note value* function is used to hold on to certain values (to freeze them). It has one numerical and one Boolean input.

If the Boolean input value is "1", then the numerical input value is output at the output. If the Boolean input value is "0", then the last output value continues to be output.

If the value is only to be applied for one flank of the Boolean input, then you can put the function *Pulse generation* upstream from it (see Chap. 9.8.6).

Inputs:	x ₁ :	<i>Input value</i> (Numerical)
	x ₂ :	<i>Switch value through</i> (Boolean)
Outputs:	y:	(Numerical)
Parameters:	-	

9.4.7 Note Minimum



The *Note minimum* function outputs the smallest value that the input value has yet reached.

If the input value is greater than the output value, then the output value remains unchanged. If the input value is less, then the output value will be reset.

The minimum can be reset with the Boolean input x₂. The input value will be applied directly at the output for as long as this input is "1".

Inputs:	x ₁ :	<i>Input value</i> (Numerical)
	x ₂ :	<i>Reset</i> (Boolean)
Outputs:	y:	(Numerical)
Parameters:	-	

9.4.8 Note Maximum



The *Note maximum* function outputs the largest value that the input value has yet reached.

If the input value is less than the output value, then the output value remains unchanged. If the input value is greater, then the output value will be reset.

The maximum can be reset using the Boolean input x_2 . The input value will be applied directly at the output for as long as this input is "1".

Inputs:	x_1 :	<i>Input value</i> (Numerical).
	x_2 :	<i>Reset</i> (Boolean)
Outputs:	y :	(Numerical)
Parameters:	-	

9.4.9 Tabular Value



With the function *Tabular value*, the output value is obtained from a parameterized number table. The input value functions as a number of the table entry at the same time.

If the whole number value of the input is 0 or less, then the first value of the table will be output; if it is 1, then the second value; and so on up to the last tabular value. If the input value is greater than the number of tabular entries, then the last table entry will be output.

As a basic rule, the input value will be rounded to a whole number. The table is defined using the *Table* parameter. Each value must have a line of its own at the time of entry. Empty lines are removed automatically. The number of values will also be defined automatically on the basis of the available lines. It must be between 2 and 20.

The *Tabular value* function can be used for example as a downstream element of a division remainder in order to simulate various values one after the other (see Chap. 9.3.5).

Inputs:	x :	<i>Index of the selected tabular value</i> (Numerical)
Outputs:	y :	<i>Selected value</i> (Numerical)
Parameters:	p_1 :	<i>Table</i> (values table)

9.4.10 Tabular Index



The *Tabular index* function is the counterpart to the *Tabular value* function. The input value is sorted into a parameterizable numerical table, which must be organized in order of increasing values, and the number of the tabular entry is output.

If, for example, the first tabular entry is 4 and the second is 7.8, then a 0 will be output for all input values less than 4, the value 1 will be output for all values between 4 and 7.8, and the value 2 for all values greater than 7.8.

The table is defined using the *Table* parameter. Each value must have a line of its own at the time of entry. Empty lines are removed automatically. The number of values will also be defined automatically on the basis of the available lines. It must be between 2 and 20.

This function can be used for flexible range definition. Thus, for example, limits can be defined in the table when a value is normal, suspicious, critical and very critical.

Inputs:	x:	<i>Value in the table</i> (Numerical).
Outputs:	y:	<i>Index of the value / Value range</i> (Numerical).
Parameters:	p ₁ :	<i>Table</i> (values table)

9.4.11 Characteristic Curve



The *Characteristic curve* function is used to convert input values from one range into another. The conversion can be subdivided into various segments through the specification of up to 20 nodes.

The *Table* parameter is used to specify the nodes. Each value pair is in a different line in the table. The values for x and y are separated by a colon. The x values must be listed in ascending order. No x value may appear more than once. Empty lines are removed automatically. The number of values will also be defined automatically on the basis of the available lines. It must be between 2 and 20.

The ranges between the nodes are interpolated linearly; the values outside the nodes are extrapolated from the last segment. A limitation is easy to set up by simply setting another node nearby that has the same y value. If for example the range of 0 to 450 is to be converted to percent and at the same time limited to 0 and 100, then this is accomplished with the following value pairs:

-1:	0
0:	0
450:	100
451:	100

Inputs:	x:	<i>X value of the characteristic curve</i> (Numerical).
Outputs:	y:	<i>Function value from the characteristic curve</i> (Numerical)
Parameters:	p ₁ :	<i>Table</i> (values table)

9.4.12 Ramp



The *Ramp* function is used to prevent rapid value changes. Under stable conditions, the input value is shown at the output. Changes of the input value are however not relayed directly to the output, but only in small steps instead. Like a slope, so to speak. Different slopes can be defined for positive and negative value modifications at the same time.

The parameters *Falling ramp* and *Rising ramp* are used to specify the maximum permissible value changes per second.

If for example the value 5 is set for *Rising ramp* and the input value jumps from 0 to 100, then the output will be only slowly increased, and it will take 20 seconds for the output value to reach 100.

Inputs:	x:	(Numerical)
Outputs:	y:	(Numerical)
Parameters:	p ₁ :	<i>Falling ramp</i> (Numerical)
	p ₂ :	<i>Rising ramp</i> (Numerical)

9.5 Counting Functions

9.5.1 Count Pulses



The *Count pulses* function has three Boolean inputs and one numerical output. If the *Counting* input has the value "1", then the changes from "0" to "1" at the *Pulses* input will be counted and the count value will be set at the output. If the *Reset* input is at "1", then the count value, and thus the output as well, will be "0".

Flexible counting structures can thus be obtained by placing the *Pulse generation* function upstream (see Chap. 9.8.6). The placement of a downstream *Note value* function (see Chap. 9.4.6) also makes it possible to provide a counter with an interim status.

Inputs:	x_1 :	<i>Pulses</i> (Boolean)
	x_2 :	<i>Counting</i> (Boolesch)
	x_3 :	<i>Reset</i> (Boolean)
Outputs:	y :	<i>Count value</i> (Numerical)
Parameters:	-	

9.5.2 Stop Watch



The *Stop watch* function has two Boolean inputs and one numerical output. If the *Start/Stop* input has the value "1", then the seconds will be counted and the time will be applied at the output. If the *Reset* input is at "1", then the time, and thus the output as well, will be "0". The behavior at the output can be controlled with the *Output* parameter.

Two settings are possible:

Current time

The output value is the current number of seconds counted.

Stopped time

The output value is not the current quantity, but rather the most recently measured quantity. This means that the current count is set to the output whenever the time is stopped with the *Start/Stop* input.

Flexible time measurement structures can thus be obtained by placing the *Pulse generation* function upstream (see Chap. 9.8.6).

Inputs:	x_1 :	<i>Start/Stop</i> (Boolean)
	x_2 :	<i>Reset</i> (Boolean)
Outputs:	y :	(Numerical)
Parameters:	p_1 :	<i>Output</i> (entry list)

9.6 Numerical Conditions

9.6.1 Equals



The *Equals* function compares two numerical input values for equivalence and outputs a "1" at its Boolean output if the values are equivalent, otherwise a "0".

With the *Precision* parameter, you can adjust how precise the comparison is. For this the following explanation:

In view of the fact that numerical values are presented on computers as floating point numbers with finite precision, normal comparisons usually fail. Thus, for example, the finite precision of $2/6$ is not necessarily the same as the result of $1/3$. The difference goes to 8 decimal places, but nonetheless the two values are not recognized as being equivalent.

The point at which one needs to break off the comparison of numbers varies from case to case. It is for that reason that you have the option of controlling the precision of the comparison.

If you specify 0.01 for precision, for example, then the numbers 12.453 and 12.458 will still be recognized as equivalents to one another, because the difference is less than 0.01.

Inputs:	x_1 :	(Numerical)
	x_2 :	(Numerical)
Outputs:	y :	(Boolean)
Parameters:	p_1 :	<i>Precision</i> (Numerical)

9.6.2 Does not Equal



The *Does not equal* function compares two numerical input values and outputs a "1" at its Boolean output if the values are not equal, otherwise a "0".

For the *Precision* parameter, see the explanation in the *Equals* function (Chapter 9.6.1).

Inputs:	x_1 :	(Numerical)
	x_2 :	(Numerical)
Outputs:	y :	(Boolean)
Parameters:	p_1 :	<i>Precision</i> (Numerical)

9.6.3 Greater than



The *Greater than* function compares two numerical input values and outputs a "1" at its Boolean output if value x_1 is greater than x_2 , otherwise a "0".

In view of the fact that numerical values are presented on computers as floating point numbers with finite precision, it is difficult to make decisions in border ranges. (See the explanation in Chapter 9.6.1, *Equals* function). This is however usually irrelevant in everyday usage, because the accuracy is to 8 significant decimal places.

When however it is important that a precise decision be made for a border range, then you can install the *Rounding* function upstream (see Chap. 9.3.8).

Inputs:	x_1 :	(Numerical)
	x_2 :	(Numerical)
Outputs:	y :	(Boolean)
Parameters:	-	

9.6.4 Greater than or Equal to



The *Greater than or equal to* function compares two numerical input values and outputs a "1" at its Boolean output if value x_1 is greater than or equal to x_2 , otherwise a "0".

For more on the subject of precision, please see the explanations in the *Greater than* function (see Chapter 9.6.3).

Inputs:	x_1 :	(Numerical)
	x_2 :	(Numerical)
Outputs:	y :	(Boolean)
Parameters:	-	

9.6.5 Less than



The *Less than* function compares two numerical input values and outputs a "1" at its Boolean output if value x_1 is less than x_2 , otherwise a "0".

For more on the subject of precision, please see the explanations in the *Greater than* function (see Chapter 9.6.3).

Inputs:	x_1 :	(Numerical)
	x_2 :	(Numerical)
Outputs:	y :	(Boolean)
Parameters:	-	

9.6.6 Less than or Equal to



The *Less than or equal to* function compares two numerical input values and outputs a "1" at its Boolean output if value x_1 is less than or equal to x_2 , otherwise a "0".

For more on the subject of precision, please see the explanations in the *Greater than* function (see Chapter 7.6.3).

Inputs:	x_1 :	(Numerical)
	x_2 :	(Numerical)
Outputs:	y :	(Boolean)
Parameters:	-	

9.6.7 Within



The *Within* function compares three numerical input values and outputs a "1" at its Boolean output if value x_1 is greater than or equal to x_2 , and smaller than or equal to x_3 , otherwise a "0".

For more on the subject of precision, please see the explanations in the *Greater than* function (see Chapter 9.6.3).

Inputs:	x_1 :	(Numerical)
	x_2 :	(Numerical)
	x_3 :	(Numerical)
Outputs:	y :	(Boolean)
Parameters:	-	

9.6.8 Outside



The *Outside* function compares three numerical input values and outputs a "1" at its Boolean output if value x_1 is smaller than x_2 or greater than x_3 , otherwise a "0".

For more on the subject of precision, please see the explanations in the *Greater than* function (see Chapter 9.6.3).

Inputs:	x_1 :	(Numerical)
	x_2 :	(Numerical)
	x_3 :	(Numerical)
Outputs:	y :	(Boolean)
Parameters:	-	

9.7 Boolean Links

9.7.1 Not



The *Not* function supplies the negated Boolean input value at its Boolean output.

If $x = "0"$, then a "1" is output, otherwise a "0".

Inputs: x : (Boolean)
 Outputs: y : (Boolean)
 Parameters: -

9.7.2 And



The *And* function links the two Boolean inputs with the "and" operation and supplies the result to its Boolean output.

The output is then "1" only if both inputs are "1", otherwise it is "0".

The following log table makes this function clear.

x_1	x_2	y
0	0	0
0	1	0
1	0	0
1	1	1

Inputs: x_1 : (Boolean)
 x_2 : (Boolean)
 Outputs: y : (Boolean)
 Parameters: -

9.7.3 Not - And



The *Not - And* function links the two Boolean inputs with the "nand" operation and supplies the result to its Boolean output.

The output is then "0" only if both inputs are "1", otherwise it is "1".

The following log table makes this function clear.

x_1	x_2	y
0	0	1
0	1	1
1	0	1
1	1	0

Inputs: x_1 : (Boolean)
 x_2 : (Boolean)
 Outputs: y : (Boolean)
 Parameters: -

9.7.4 Or



The *Or* function links the two Boolean inputs with the "or" operation and supplies the result to its Boolean output.

The output is "1" if one of the two inputs is "1". If both are "0", then the output will also be "0".

The following log table makes this function clear.

X_1	X_2	Y
0	0	0
0	1	1
1	0	1
1	1	1

Inputs: x_1 : (Boolean)
 x_2 : (Boolean)
 Outputs: y : (Boolean)
 Parameters: -

9.7.5 Not - Or



The *Not - Or* function links the two Boolean inputs with the "nor" operation and supplies the result to its Boolean output.

The output is "0" if one of the two inputs is "1". If both of the inputs are "0", then the output will be "1".

The following log table makes this function clear.

X_1	X_2	Y
0	0	1
0	1	0
1	0	0
1	1	0

Inputs: x_1 : (Boolean)
 x_2 : (Boolean)
 Outputs: y : (Boolean)
 Parameters: -

9.7.6 Exclusive Or



The *Exclusive Or* function links the two Boolean inputs with the "xor" operation and supplies the result to its Boolean output.

The output is "1" if precisely one of the two inputs is "1". If both of the inputs are "0" or if both of the inputs are "1", then the output will be "0". One can also say that the output is then precisely "1" if the two inputs are not equal.

The following log table makes this function clear.

x_1	x_2	y
0	0	0
0	1	1
1	0	1
1	1	0

Inputs: x_1 : (Boolean)
 x_2 : (Boolean)
 Outputs: y : (Boolean)
 Parameters: -

9.7.7 Not Exclusive Or



The *Not Exclusive Or* function links the two Boolean inputs with the "nxor" operation and supplies the result to its Boolean output.

The output is "0" if precisely one of the two inputs is "1". If both of the inputs are "0" or if both of the inputs are "1", then the output will be "1". One can also say that the output is then precisely "1" if the two inputs are equal.

The following log table makes this function clear.

x_1	x_2	y
0	0	1
0	1	0
1	0	0
1	1	1

Inputs: x_1 : (Boolean)
 x_2 : (Boolean)
 Outputs: y : (Boolean)
 Parameters: -

9.8 Other Boolean Operations

9.8.1 Note Switching Status



The *Note switching status* function is used to hold on to a Boolean value (to freeze it). It has two Boolean inputs.

If the input value x_2 is "1", then the input value x_1 is output at the output. If the input value x_2 is "0", then the last output value remains in effect.

If the value is only to be applied for one flank, then you can put the function *Pulse generation* upstream at x_2 (see Chap. 9.8.6).

Inputs:	x_1 :	<i>Value</i> (Boolean)
	x_2 :	<i>Note</i> (Boolean)
Outputs:	y :	(Boolean)
Parameters:	-	

9.8.2 Switching Delay



The *Switching delay* function is used to delay Boolean signals. The function has one Boolean input and one Boolean output. A change at the input will not be recognizable at the output until after a parameterizable delay time has elapsed.

The delay times can be set separately for switching on and switching off. They are adjusted with the parameters *Switch-on delay* and *Switch-off delay*. This makes it possible to hide short-term signal changes from view.

Example:

Input and output are "0", the switch-on delay is set to 5 seconds. If the input switches now to "1", then the output waits 5 seconds before switching to "1". If the input switches back to "0" before the 5 seconds have elapsed, then the input remains set to "0" and the change at the input is not visible at all at the output.

Inputs:	x :	(Boolean)
Outputs:	y :	(Boolean)
Parameters:	p_1 :	<i>Switch-on delay</i> in seconds (Numerical)
	p_2 :	<i>Switch-off delay</i> in seconds (Numerical)

9.8.3 T - Flipflop



The *T-FlipFlop* function is the representation of a surge relay. The output switches over every time the Boolean input value changes from "0" to "1". (Toggle function, hence the name T-Flipflop).

A side effect of the T-FlipFlop is that it halves the frequency of a counting signal.

The output is set to 0 after initialization at the time of program start.

Inputs:	x:	(Boolean)
Outputs:	y:	(Boolean)
Parameters:	-	

9.8.4 Mono Flop



The output switches on when the Boolean input value switches from "0" to "1". The function is comparable to the automatic switching of a light in a stairwell.

The output is set to 0 after initialization at the time of program start.

When the Reset input is set to "1", then the output is definitely set to "0".

- *Not retriggerable*
When the flank switches from "0" to "1", the output for the specified time is switched to "1". After the time elapses, the output is set back to "0". It doesn't matter whether or not this flank occurs again during this time.
- *Retriggerable*
When the flank switches from "0" to "1", the output for the specified time is switched to "1". After the time elapses, the output is set back to "0". If the flank switches from "0" to "1" once again during this time, then the output will be switched again to "1" for the time specified.
- *Prolongable*
When the flank switches from "0" to "1", the output for the specified time is switched to "1". If no change of flanks occurred during this time, then the output remains switched to "1" until the flank switches from "1" to "0".

Inputs:	x_0 :	S (Boolean)
	x^1 :	R (Boolean)
Outputs:	y:	(Boolean)
Parameters:	p1:	Mode
	p2:	Time in seconds

9.8.5 RS - Flipflop



The *RS-FlipFlop* function has a Boolean input *Set* for the purpose of setting the output to "1" and a Boolean input *Reset* for setting the output back to "0".

The *Priority* parameter can be used to define how the output will react when a "1" is present at both inputs simultaneously. The following priorities are possible:

First

If the Set input is the first to switch to "1", then the output is "1"; if the Reset input is the first to switch to "1", then the output is "0". If both switch to "1" simultaneously, then the output remains in its present status.

Last

If the Set input is the last to switch to "1", then the output is "1"; if the Reset input is the last to switch to "1", then the output is "0". If both switch to "1" simultaneously, then the output remains in its present status.

Off

The output value is "0"

On

The output value is "1"

The output is set to 0 after initialization at the time of program start.

Inputs:	x_0 :	S (Boolean)
	x_1 :	R (Boolean)
Outputs:	y:	(Boolean)
Parameters:	p_1 :	Priority (entry list)

9.8.6 Pulse Generation



The *Pulse generation* function is used for generating a Boolean pulse. Every time the input changes from "0" to "1", the output is set to "1" for a cycle.

This function is useful with the Note functions (Note value, Note minimum, etc.), among others.

Inputs:	x:	(Boolean)
Outputs:	y:	(Boolean)
Parameters:	-	

9.9 Result Values

9.9.1 Numerical Output Value



The *Numerical output value* function makes a numerical input value available to the outside. It publishes the value.

Output values are displayed in the measured value display of a connected PC. A maximum of 32 values can be published.

The values are published in a fixed decimal point representation. The number of decimal places must be entered using the *Decimal format* parameter for this purpose. The current format allows only 5 significant places and the first only goes up to 3. The maximum number ranges are therefore as follows:

<u>Decimal format</u>	<u>maximum value range</u>
0	-30000 ..+30000
0.0	-3000.0 ..+3000.0
0.00	-300.00 ..+300.00
0	-30.000 ..+30.000

The output value is always limited to the above-mentioned maximum value range. The decimal format must be adjusted to be able to display all of the values relevant to practical requirement. If required, one can for example publish a "bar" value in "millibars" by multiplying the value by 1000.

The *Designation* parameter defines the name under which the value is displayed. The *Unit* parameter defines the physical unit. No two output values are permitted to have the same name.

The *Low range* and *High range* parameters are used solely for defining the typical value range for post-processing work. If, for example, the value progression is output as a graphic, then the graphics program will first scale the values to the value range specified here. The specification of the measurement range has no effect on the limitation of the output value.

Example: "0.00" is set as the decimal format, "250.00" as the upper measuring range. If the input value is now 450.00, then the value 300.00 will be publicized, because limiting is based on the maximum value range and not on the upper measuring range.

If this behavior is not wanted, limit the value using the *Limit* function (see Chap. 9.4.3).

Inputs:	x:	(Numerical)
Outputs:	-	
Parameters:	p ₁ :	<i>Designation</i> (character string)
	p ₂ :	<i>Lower range</i> (Numerical)
	p ₃ :	<i>Upper range</i> (Numerical)
	p ₄ :	<i>Unit</i> : (character string)
	p ₅ :	<i>Decimal format</i> : (input list)

9.9.2 Boolean Output Value



The *Boolean output value* function makes a Boolean input value available to the outside. It publishes this value.

A connected PC indicates the status values in the status line. A maximum of 15 status values can be publicized.

All status values are combined to make a common status in the results log. Each individual status value is represented as one Bit. The question of which Bit will be used is defined in the *Bit number* parameter.

No two status values are permitted to have the same Bit number.

Inputs:	x:	(Boolean)
Outputs:	-	
Parameters:	p ₁ :	<i>Bit number</i> (whole number)

9.10 Actions

9.10.1 Setting Switching Output



The *Set switch output* function transmits the Boolean input to a digital switching output on the CM device.

The *Output terminal* parameter is used to define which digital output port is used.

Inputs: x: (Boolean)
 Outputs: -
 Parameters: p₁: *Output terminal* (input list)

9.10.2 Switch on LED



The *Switch on LED* function has one Boolean input. The relevant LED will remain on for as long as the input value is "1".

The *Acknowledge* parameter is disregarded on the CSI-F-10 platform because this device does not have the facility to acknowledge LEDs as it does not have the required buttons.

Each LED may only be used once in the CM program.

Depending on the precise CM device, the LEDs can have different designations, e.g.: red, green, LED1, LED2, etc.

Inputs: x: (Boolean)
 Outputs: -
 Parameters: p₁: *Color* (entry list)
 p₂: *Acknowledgement* (Boolean)

9.10.3 Send SMS



The *Send SMS* function is used to send an SMS when an event occurs. This occurs every time the input value changes from "0" to "1".

The text of the SMS is defined with the *Message* parameter and the *Telephone number* parameter defines the number to which the SMS is sent.

Inputs: x: (Boolean)
 Outputs: -
 Parameters: p₁: *Telephone number* (character string)
 p₂: *Message* (character string)

9.11 Other

9.11.1 Comment



With the *Comment* function, it is possible to insert a comment at any given point in the CM program.

The heading of the Comment box is defined with the *Inscription* parameter.

The actual comment text is entered with the *Comment* parameter.

Inputs: -
Outputs: -
Parameters: p₁: *Inscription* (character string)
 p₂: *Comment* (character string)

10 Error Messages CM Program Compilation

In order to ensure as high a degree of operational safety as possible, the CM program generated will be checked for possible programming errors before it is transferred into the device. If the system detects one or more such programming errors, then the following message will appear and the CM program will not be transferred in the CSI-F-10.

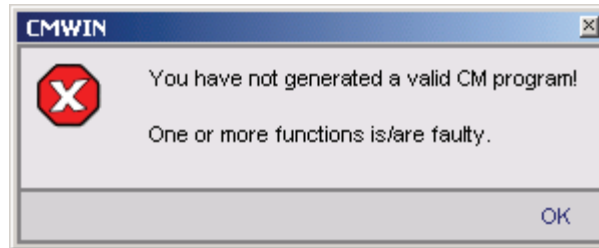

The menu function [*CM Program / Display*] (see Chap. 8.1.2) can be used in such cases to have a more detailed program evaluation displayed, together with error messages, and to have this printed out as needed.

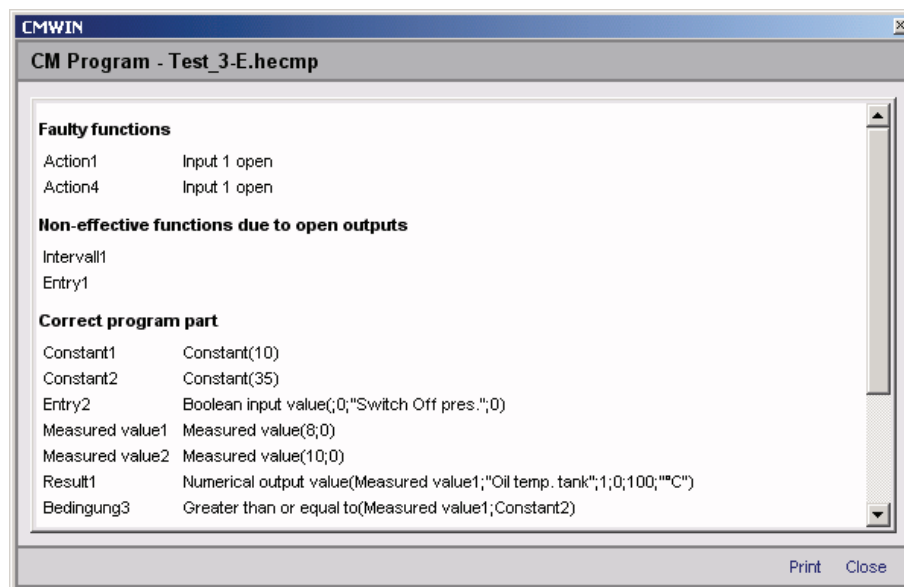

Work through all of the error messages in your CM program and then transfer the program once again into your CSI-F-10.

The following list shows all of the error messages that could occur during programming, together with the associated function groups present in CMWIN, and their causes.

10.1 Overriding Error Messages

10.1.1 Function not Available in this Mode

The CM program has been compiled for a platform in which the marked function does not exist.

- ▶ Check the platform setting and correct it or modify the CM program accordingly.

10.2 Error Messages with Data Sources

10.2.1 Invalid Channel Setting

A channel/subchannel has been selected that is not valid.

- ▶ Check the channel setting and correct it.

10.2.2 Duplicate Channel Name

The name of a channel may only be used once in a CM program.

- ▶ Check the channel name and correct it.

10.2.3 Invalid Digital Input

A port must be set for the digital input function.

- ▶ Check the port setting and correct it.

10.2.4 Duplicate Digital Input

A port must be set for the digital input function. This set port may only be used once in a CM program.

- ▶ Check the port setting and correct it.

10.2.5 Too many Boolean Input Fields

A maximum of 50 Boolean input values are permitted to be present in a single CM program.

- ▶ Reduce the Boolean input values to a maximum of 50.

10.2.6 No Inscription for Boolean Input

The Boolean input value must have an inscription.

- ▶ Enter an inscription in the function properties.

10.2.7 Duplicate Inscription for Boolean Inputs

The inscription of a Boolean input value must be unambiguous within a CM program and is only permitted to occur once for that reason.

- ▶ Check the inscription and correct it.

10.2.8 Too Many Numerical Input Values

A maximum of 50 numerical input values are permitted to be present in a single CM program.

- ▶ Reduce the numerical input values to a maximum of 50.

10.2.9 No Inscription for Numerical Input

The numerical input value must have an inscription.

- ▶ Enter an inscription in the function properties.

10.2.10 Duplicate Inscription for Numerical Input

The inscription of a numerical input value must be unambiguous within a CM program and is only permitted to occur once for that reason.

- ▶ Check the inscription and correct it.

10.2.11 Duplicate Error Source

A setting is made for an error source to indicate which error will be the output of the error source. No error source may be present more than once in a CM program.

- ▶ Check the setting under "Error messages" and correct it.

10.3 Error Messages for Operations/Conditions

10.3.1 Upper and Lower Measured Value Limits too Close to one another

For functions with upper and lower value limits, the two values must be at least 10 steps apart.

- ▶ Check the values that were entered and correct them.

10.3.2 Measured Value Limits Outside the Range of -30000 to 30000

For functions with upper and lower value limits, the entered values must be between -30,000 and +30,000.

- ▶ Check the values that were entered and correct them.

10.3.3 Lower Measured Value Limit Greater than Upper Measurement Value Limit

For functions with upper and lower measured value limits, the lower measured value must be less than the upper measured value.

- ▶ Check the values that were entered and correct them.

10.4 Error Messages with Result Values/Actions

10.4.1 Invalid Output LED Selected

The selected LED does not exist in this device and must be set correctly.

- ▶ Check the LED setting and correct it.

10.4.2 Duplicate Use of Output LED

The selected LED is already being used in the current CM program and may not appear twice.

- ▶ Check the LED selection and correct it.

10.4.3 Invalid Digital Output

The quantity of digital outputs is device-dependent. This error is set when an output terminal is selected that a device doesn't have.

- ▶ Check the selection and correct it.

10.4.4 Duplicate Digital Output

The output terminal of the digital output must not occur more than once in a CM program.

- ▶ Check the output terminal which has been set and correct it.

10.4.5 Too Many Boolean Output Fields

The quantity of Boolean output fields in one CM program is device-dependent.

- ▶ Reduce the Boolean output fields to the device-specific maximum.

10.4.6 Duplicate Boolean Output Field

The inscription of a Boolean output field must not occur more than once in a CM program.

- ▶ Check the inscription and correct it.

10.4.7 The Bit Number Must Be a Figure between 0 and 14

The property "Bit number" must not lie outside the range of 0 ... 14 for the Boolean output field function.

- ▶ Check the value that was entered and correct it.

10.4.8 Too Many Numerical Output Fields

The quantity of numerical output fields in one CM program is device-dependent.

- ▶ Reduce the numerical output fields to the device-specific maximum.

10.4.9 Duplicate Numerical Output Field

The inscription of a numerical output field must not be present more than once in a CM program.

- ▶ Check the inscription and correct it.

10.4.10 Message and telephone number too long

The length of the message + telephone number together is limited to 230 characters.

- ▶ Check the relevant entries and correct them.

11 Specifications

11.1 Power Supply

- Input voltage: 10.5 ... 35.0 V DC
- Residual ripple: $\leq 5 \%$
- Current consumption without sensors and outputs:
 - Typical (mean value): ≤ 90 mA Stand-By / ≤ 200 mA with radio connection
 - Pulsed: ≤ 2 A (power supply recommendation: 3.5 A)
- Reverse voltage protection: -35 V

11.2 Sensor Inputs

(5 pole female connection "Sensor 1", 8 pole female connection "Sensor 2")

A maximum of 2 SMART sensors can be connected.

- Output voltage (+U_{B out}): +U_{B in} - 0.5V
- Current supply: max. 500mA at 50°C

11.3 Logic measurement channels

A total of up to 32 measurement channels can be processed by the CSI-F-10.

A measurement channel can be a sub-channel of a SMART sensor or a value derived (calculated) from sensor data.

11.4 Digital Inputs and Outputs (8 pole female connection "In/Out")

- Output voltage (+U_{B out}): +U_{B in} - 0.5 V
- Current supply (incl. outputs): max. 500 mA at 50 °C
- Inputs
 - Quantity: 4
 - Input voltage: 0 ... 35.0 V DC
 - Trigger threshold: Low: < 0.8 V; High: > 5.0 V
 - Input current consumption: approx. 4 mA
- Outputs
 - Quantity: 2
 - Switching capacity (per output): + U_{B out} / 0.2 A

11.5 Interfaces

HSI bus

Mobile radio network: GSM 850 / 900 (2W (EGSM))
GSM 1800 / 1900 (1W (EGSM))

Antenna 50Ω FME plug

SIM: 3V SIM card

11.6 Cycle Time

The CSI-F-10 identifies the required cycle time automatically when the program starts. The user has the option of having the current cycle time displayed on the CM Editor. The minimum cycle time amounts to 500 ms.

11.7 Operating and Ambient Conditions

Operating temperature: -10.. .. +55 °C (GSM 1800 / 1900)
-20 .. +55 °C (GSM 850 / 900)
Storage temperature: -30 .. +65°C
Relative humidity: 0 .. 70%, non-condensing

11.8 Dimensions and Weight:

Dimensions: approx. 145 x 95 x 55 mm (B x H x D) without antenna
Weight: approx. 350 g

11.9 Technical Standards

EMC: Conformity with R&TTE Directive 1999/5/EC, EN 61000-6-1/2/3/4
Safety: EN 60950 / EN 61010
Protection class: IP 65

11.10 Items supplied

The CSI-F-10 is packed in a box and is supplied ready-for-operation. Prior to installation, check the packaging and the device for transit damage and ensure that all the parts are present.

- CSI-F-10 (incl. 90° angle antenna and 2.5 m wire antenna)
- User manual
- CD-ROM with the PC software "CMWIN" as well as additional product information

11.11 Maintenance and cleaning

- De-energize the CSI-F-10 and verify that it is free of voltage.
- For reasons of electrical safety, never clean the device with water or other fluids, and under no circumstances whatsoever should the device be immersed in water or other fluids.
- Use only a dry, lint-free cloth for cleaning. Do not use any solvents, gasoline or similar, as these would damage the CSI-F-10.

11.12 Recycling and Disposal

The packing and the packing material are composed solely of environmentally friendly materials. They can be disposed of in the appropriate local recycling containers.

Never dispose of electrical devices and electronic components in containers intended for household refuse!

Pursuant to European Guideline 2002/96/EU concerning used electrical and electronic devices and implementation in national law, used electrical devices must be collected separately and must be recycled in accordance with environmental standards.

A company certified for the disposal of electronic waste must be consulted in this regard in order to ensure that your device is recycled or disposed of in an environmentally friendly manner.

12 Ordering Details

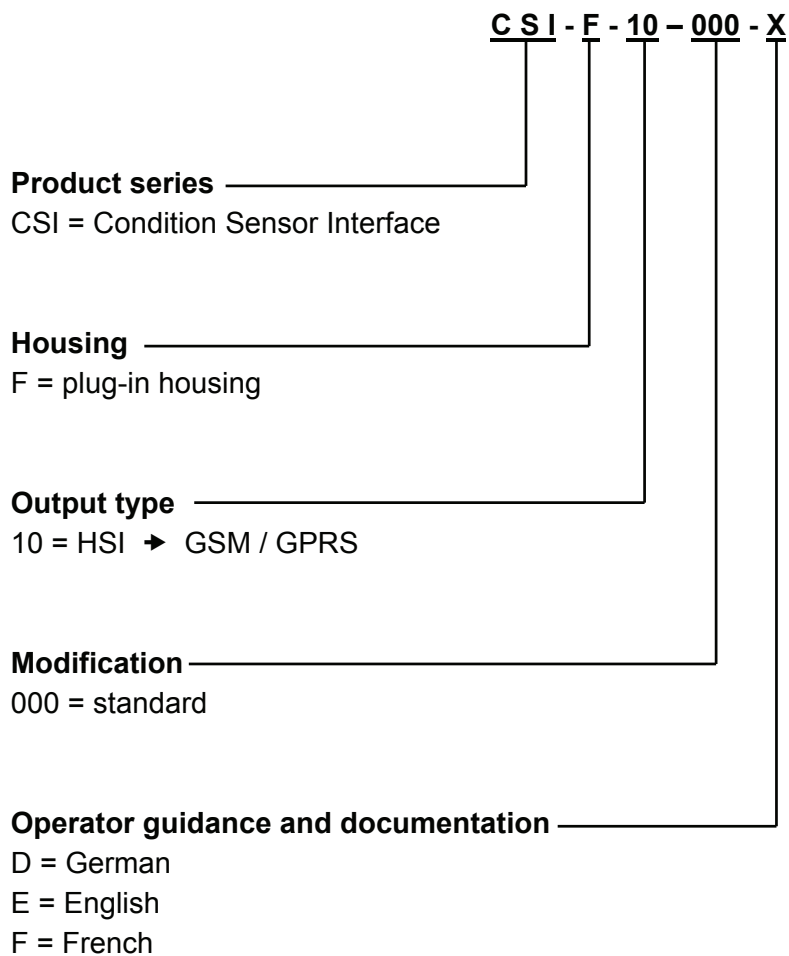

13 Exclusion of liability

The HYDAC CSI-F-10 GSM radio module communicates via the GSM mobile radio network. There is always the possibility therefore that the GSM services used by the CSI-F-10 will be affected by any failures in the relevant network operator. This situation lies outside the control of HYDAC ELECTRONIC and is also outside our sphere of influence.

For this reason, HYDAC ELECTRONIC is not liable for the evaluation and / or execution of sent or received data, messages, control instructions, etc from and to the CSI-F-10 GSM radio module.

14 Accessories

• SMART Sensors

HLB 1300 - Series	(oil condition sensor)
AS 1000 - Series	(humidity sensor)
CS 1000 - Series	(contamination sensor)

• Connection adapters

Part no. 3304374	Part Desig. ZBE 26 (Y adapter, blue for HLB 1000)
Part no. 909737	Part Desig. ZBE 36 (connection adapter for AS 1000)
Part no. 3224436	Part Desig. ZBE 38 (Y adapter black)
Part no. 910000	Part Desig. ZBE 41 (Y adapter, yellow for CS 1000)

• Female connectors

Part no. 6006788	Part Desig. ZBE 06 female connector M12x1, 4 pole, right-angle
Part no. 6006790	Part Desig. ZBE 06-02 fem. connector M12x1, 4 pole with 2m cable
Part no. 6006789	Part Desig. ZBE 06-05 fem. connector M12x1, 4 pole with 5m cable
Part no. 6006786	Part Desig. ZBE 08 female connector M12x1, 5 pole, right-angle
Part no. 6006792	Part Desig. ZBE 08-02 female connector M12x1, 5 pole with 2m cable
Part no. 6006791	Part Desig. ZBE 08-05 female connector M12x1, 5 pole with 5m cable
Part no. 6055444	Part Desig. ZBE 0P female connector M12x1, 8 pole, right-angle
Part no. 6052697	Part Desig. ZBE 0P-02 fem. connector M12x1, 8 pole with 2m cable
Part no. 6052698	Part Desig. ZBE 0P-05 fem. connector M12x1, 8 pole with 5m cable

• Connection cables

Part no. 6040851	Part Desig. ZBE 30-02 sensor cable M12x1, 5 pole; 2m
Part no. . 6040852	Part Desig. ZBE 30-05 sensor cable M12x1, 5 pole; 5m
Part no. 3281240	Part Desig. ZBE 43-05 sensor cable M12x1, 8 pole; 5m

HYDAC ELECTRONIC GMBH

Hauptstrasse 27
D-66128 Saarbrücken, Germany
Germany

Web : www.hydac.com
E-mail : electronic@hydac.com
Tel.: +49-(0)6897-509-01
Fax: +49-(0)6897-509-1726

HYDAC Service

If you have any questions concerning repair work, please do not hesitate to contact HYDAC Service:

HYDAC SERVICE GMBH

Hauptstr.27
D-66128 Saarbrücken, Germany
Germany

Tel.: +49-(0)6897-509-1936
Fax: +49-(0)6897-509-1933

Notice

The information in this manual relates to the operating conditions and applications described. For applications and operating conditions not described, please contact the relevant technical department concerned.

If you have any questions, suggestions, or encounter any problems of a technical nature, please contact your HYDAC representative.

Subject to technical modifications.